



Mobile Networks



Jumper cable



Feeder cable + connector



Cable clamp



Grounding kit



Contents



Antenna Line Products and Contents	2-3
Draka - Your Reliable Partner	4-5
Mobile Network Products	6-7
Feeder Cables	8-9
RFA 1/4"	10-11
RFA 3/8"	12-13
RFA 1/2"	14-15
RFA 7/8"	16-17
RFA 7/8" AL	18-19
RFA 1 1/4"	20-21
RFA 1 5/8"	22-23
RFA 1 5/8" AL	24-25
RFA 2 1/4"	26-27
Superflexible and Extraflexible Cables	28-29
RFF 1/4"	30-31
RFF 3/8"	32-33
RFF 1/2"	34-35
RFE 7/8"	36-37
RFE 1 1/4"	38-39
RFE 1 5/8"	40-41
Coaxial Antennas	42-43
RFX 1/2"	44-45
RFX 7/8"	46-47
RFX 1 1/4"	48-49
RFX 1 5/8"	50-51
RFXT 7/8"	52-53
RFXT 1 1/4"	54-55
Jumpers	56-57
Accessories	58-59
Drums	60-61
Environment and Quality	62-65
How to contact us	66-67

All information in this catalog is subject to change without prior notice.

Draka - Your Reliable Partner





Draka is one of the leading cable manufacturers in the world today. Draka companies are engaged in the development, production and sales of cables and cable systems worldwide. Based on our long experience and expertise in cable manufacturing, we are today one of the most reliable cable suppliers.

We are committed to offering our customers a technically advanced product portfolio and competent service. An essential part of our philosophy is to implement constant improvements and to develop new products and services to provide value for our customers on a sustainable basis.

Draka is a guarantee of outstanding performance in all relevant circumstances.

You will find more information about Draka at www.draka.com.



Mobile Network Cable Products





Draka offers a wide range of products with guaranteed compatibility and reliability for mobile networks. In this catalogue you will find Mobile Network Cable products: feeder cables, coaxial antennas, superflexible cables and jumpers. Accessories are presented at the end of the catalogue.

Our production facilities located in Finland and China are equipped with modern production lines, and we can provide products from leading connector and accessory manufacturers through our extensive partner network. To ensure prompt deliveries, we have established our own distribution centers in different parts of the world. Flexible customer service is one of our strengths and our extensive resale network serves our customers locally worldwide.

Draka feeder cables, flexible cables and coaxial antennas have outstanding performance in mobile telecommunication applications, such as GSM, WCDMA (UMTS), TDMA, D-AMPS, PCN, CDMA and TETRA. They are also used in some other applications e.g. WiMAX and broadcasting. Our cables have been designed to transmit signal power between the transmission equipment and the antenna even in most demanding environmental conditions and thus meet the highest technical and environmental standards.

All of our cables are halogen free and non corrosive. They are available in standard polyethylene jacket and in fire retardant, low smoke emission jacket in black (BHF) or grey (GHF). Our cables and jumpers comply with the European Union RoHS directive (Restriction of Hazardous Substances).





Feeder Cables

Our feeder cable family, RFA, has been designed to meet the highest technical standards. Enhanced electrical values, uniform impedance and low attenuation at high frequencies make RFA an optimal choice for all applications including UMTS and WiMAX. Our RFA cables are compatible with standard connectors and accessories.

RFA cables' unique two layer jacketing with harder HDPE surface and softer LDPE inside gives the cable best protection in all installation environments without losing flexibility. In our cables, the foam dielectric has an extremely high degree of expansion and a special skin layer for extra protection.

Draka 50 Ohm Radio Frequency Cables

FEEDER CABLES						
Type	Product code	Inner conductor diam. mm (in)	Outer conductor diam. mm (in)	Jacket diam. mm (in)	Standard length m (ft)	Standard drum type
RFA 1/4"-50	NKRFA01400	2.4 (0.09)	7.5 (0.3)	10.0 (0.39)	500 (1640)	P6D
RFA 3/8"-50	NKRFA03800	3.1 (0.12)	9.5 (0.37)	11.2 (0.44)	250 (820)	P6D
RFA 1/2"-50	NKRFA01200	4.8 (0.19)	13.9 (0.55)	16.0 (0.63)	500 (1640)	P11D
RFA 7/8"-50	NKRFA07800	9.4 (0.37)	25.4 (1.00)	27.8 (1.09)	500 (1640)	P13G
RFA 7/8"-50 AL	NKRFAL07800	9.4 (0.37)	25.4 (1.00)	28.0 (1.10)	500 (1640)	P13G
RFA 1 1/4"-50	NKRFA11400	13.0 (0.51)	35.8 (1.41)	39.0 (1.54)	600 (1968)	P20G
RFA 1 5/8"-50	NKRFA15800	17.6 (0.69)	46.3 (1.82)	50.0 (1.97)	400 (1312)	P20G
RFA 1 5/8"-50 AL	NKRFAL15800	17.5 (0.69)	46.5 (1.83)	50.0 (1.97)	400 (1312)	P20G
RFA 2 1/4"-50	NKRFA21400	21.2 (0.83)	55.9 (2.20)	60.0 (2.36)	300 (984)	P21Q



Feeder cable

RFA 1/4"-50

Specifications

COAXIAL CABLE	
Type	Code
RFA 1/4"-50	NKRFA01400
RFA 1/4"-50 GHF	NKRFA01401
RFA 1/4"-50 BHF	NKRFA01402
RFA 1/4"-50 BHF (UL) CATVR	NKRFA01404

CONSTRUCTION

Inner conductor	Copper-clad aluminium wire	Ø 2.4 mm	(0.09 in)
Dielectric	Cellular polyethylene	Ø 6.0 mm	(0.24 in)
Outer conductor	Corrugated copper tube	Ø 7.5 mm	(0.3 in)
Jacket	See Jacketing Options table below	Ø 10.0 mm	(0.39 in)
Marking	Draka, cable type, manufacture week, year, batch number and meter mark		

ELECTRICAL CHARACTERISTICS at +20°C (+ 68°F)

Characteristic impedance	50 ± 1 Ω
Return loss 24 dB for 100 m (330ft) cable with NKC connectors for following frequency bands:	
• 380-500 MHz	
• 806-960 MHz	
• 1710-1880 MHz	
• 1900-2170 MHz	
Other bands also available on request	
Bands according to customer's specifications	
Attenuation	See attenuation table
Velocity factor	0.83
Capacitance	80 pF/m (24 pF/ft)
Maximum frequency	16 000 MHz
Max power rating	See table
Peak RF voltage rating	1.04 kV
Peak power rating	11.6 kW
DC-resistance	
• Inner conductor	5.55 Ω/km (1.69 Ω/1000ft)
• Outer conductor	4.11 Ω/km (1.25 Ω/1000ft)

JACKETING OPTIONS							
Type	Jacket	IEC 60754 -1/-2 halogen free, non corrosive	IEC 61034 low smoke emission	IEC 60332-3-24 fire retardant	UV Retardancy	UL Rated	Min. installation temperature
RFA 1/4"-50	Black, halogen free polyethylene	yes	no	no	yes	no	-40°C (-40°F)
RFA 1/4"-50 GHF	Grey, halogen free fire retardant thermoplastic	yes	yes	yes	no	no	-20°C (-4°F)
RFA 1/4"-50 BHF	Black, halogen free fire retardant thermoplastic	yes	yes	yes	yes	no	-20°C (-4°F)
RFA 1/4"-50 BHF (UL) CATVR	Black, halogen free fire retardant UL Riser rated jacket	yes	yes	yes	yes	yes	-20°C (-4°F)

ATTENUATION			
Frequency MHz	Attenuation dB/100 m	Attenuation dB/100 ft	Power rating kW
10	1.31	(0.399)	5.5
30	2.28	(0.694)	3.2
50	2.95	(0.899)	2.5
88	3.93	(1.20)	1.8
100	4.19	(1.28)	1.7
108	4.36	(1.33)	1.7
150	5.16	(1.57)	1.4
174	5.56	(1.70)	1.3
200	5.98	(1.82)	1.2
300	7.36	(2.24)	1.0
400	8.54	(2.60)	0.85
450	9.08	(2.77)	0.80
500	9.59	(2.92)	0.75
512	9.71	(2.96)	0.74
600	10.5	(3.21)	0.69
700	11.4	(3.48)	0.63
800	12.3	(3.74)	0.59
850	12.7	(3.86)	0.57
890	13.0	(3.95)	0.56
900	13.0	(3.98)	0.55
950	13.4	(4.09)	0.54
960	13.5	(4.11)	0.54
1000	13.8	(4.20)	0.52
1200	15.2	(4.63)	0.48
1400	16.5	(5.02)	0.44
1600	17.7	(5.39)	0.41
1800	18.8	(5.75)	0.38
1900	19.4	(5.91)	0.37
2000	19.9	(6.08)	0.36
2200	21.0	(6.40)	0.34
2400	22.0	(6.71)	0.33
2600	23.0	(7.01)	0.32
2800	23.9	(7.30)	0.30
3000	24.9	(7.58)	0.29
3400	26.6	(8.11)	0.27
6000	36.5	(11.1)	0.20
8000	43.0	(13.1)	0.17
10000	48.9	(14.9)	0.15
12000	54.3	(16.6)	0.14
16000	64.4	(19.6)	0.11

Attenuation values are typical at ambient temperature +20°C (+68°F). Power rating ambient temperature +40°C (+104°F), inner conductor +100°C (+212°F).

MECHANICAL CHARACTERISTICS

Weight	0.12 kg/m	(0.08 lb/ft)
Maximum pulling force	790 N	(177 lb)
Minimum bending radius		
• Single bending	40 mm	(1.6 in)
• Repeated bending	100 mm	(3.9 in)
Operating temperature range	-55...+80°C	(-67...+176°F)
Crush resistance	1.9 kg/mm	(106 lb/in)
Bending moment	1.8 Nm	(1.3 lb-ft)
Recommended clamp spacing	0.6 m	(2 ft)

STANDARD DRUM

Cable type	Drum	Standard length m (ft)	Outer diam. (D) cm (in)	Outer width (W) cm (in)	Drum weight (empty) kg (lb)	Total weight kg (lb)	Drum freight volume m ³ (cu.ft)
RFA 1/4"	P6D	500 (1640)	63 (25)	51 (20)	13 (29)	83 (116)	0.20 (7.06)

CODES FOR NKC CONNECTORS

Connector type	Code
7-16 male	NKC1014100
N male	NKC1014300
N female	NKC1014400
N male Right angle	NKC1014600



Feeder cable

RFA 3/8''-50

Specifications

COAXIAL CABLE	
Type	Code
RFA 3/8''-50	NKRFA03800
RFA 3/8''-50 GHF	NKRFA03801
RFA 3/8''-50 BHF	NKRFA03802
RFA 3/8''-50 BHF (UL) CATVR	NKRFA03804

CONSTRUCTION

Inner conductor	Copper-clad aluminium wire	Ø 3.1 mm	(0.12 in)
Dielectric	Cellular polyethylene	Ø 8.0 mm	(0.32 in)
Outer conductor	Corrugated copper tube	Ø 9.5 mm	(0.37 in)
Jacket	See Jacketing Options table below	Ø 11.2 mm	(0.44 in)
Marking	Draka, cable type, manufacture week, year, batch number and meter mark		

ELECTRICAL CHARACTERISTICS at +20°C (+ 68°F)

Characteristic impedance	50 ± 1 Ω
Return loss 24 dB for 100 m (330ft) cable with NKC connectors for following frequency bands:	
• 380-500 MHz	
• 806-960 MHz	
• 1710-1880 MHz	
• 1900-2170 MHz	
Other bands also available on request	
Bands according to customer's specifications	
Attenuation	See attenuation table
Velocity factor	0.86
Capacitance	78 pF/m (24 pF/ft)
Maximum frequency	14 000 MHz
Max power rating	See table
Peak RF voltage rating	1.2 kV
Peak power rating	16.1 kW
DC-resistance	
• Inner conductor	3.6 Ω/km (1.10 Ω/1000ft)
• Outer conductor	3.1 Ω/km (0.94 Ω/1000ft)

JACKETING OPTIONS							
Type	Jacket	IEC 60754 -1/-2 halogen free, non corrosive	IEC 61034 low smoke emission	IEC 60332-3-24 fire retardant	UV Retardancy	UL Rated	Min. installation temperature
RFA 3/8''-50	Black, halogen free polyethylene	yes	no	no	yes	no	-40°C (-40°F)
RFA 3/8''-50 GHF	Grey, halogen free fire retardant thermoplastic	yes	yes	yes	no	no	-20°C (-4°F)
RFA 3/8''-50 BHF	Black, halogen free fire retardant thermoplastic	yes	yes	yes	yes	no	-20°C (-4°F)
RFA 3/8''-50 BHF (UL) CATVR	Black, halogen free fire retardant UL Riser rated jacket	yes	yes	yes	yes	yes	-20°C (-4°F)

ATTENUATION			
Frequency MHz	Attenuation dB/100 m	Attenuation dB/100 ft	Power rating kW
10	1.02	(0.31)	6.8
30	1.78	(0.54)	3.9
50	2.31	(0.70)	3.0
88	3.08	(0.94)	2.2
100	3.29	(1.00)	2.1
108	3.42	(1.04)	2.0
174	4.37	(1.33)	1.6
200	4.70	(1.43)	1.5
300	5.79	(1.77)	1.2
400	6.73	(2.05)	1.0
450	7.16	(2.18)	0.97
500	7.57	(2.31)	0.92
512	7.67	(2.34)	0.90
600	8.34	(2.54)	0.83
700	9.04	(2.76)	0.77
800	9.71	(2.96)	0.71
850	10.0	(3.06)	0.69
890	10.3	(3.13)	0.67
900	10.3	(3.15)	0.67
950	10.6	(3.24)	0.65
960	10.7	(3.26)	0.65
1000	10.9	(3.34)	0.63
1200	12.1	(3.68)	0.57
1400	13.1	(4.00)	0.53
1600	14.1	(4.30)	0.49
1800	15.0	(4.59)	0.46
1900	15.5	(4.72)	0.45
2000	15.9	(4.86)	0.43
2200	16.8	(5.12)	0.41
2400	17.6	(5.37)	0.39
2600	18.4	(5.62)	0.38
2800	19.2	(5.86)	0.36
3000	20.0	(6.09)	0.35
3400	21.4	(6.53)	0.32
6000	29.6	(9.04)	0.24
13500	48.1	(14.7)	0.15

Attenuation values are typical at ambient temperature +20°C (+68°F). Power rating ambient temperature +40°C (+104°F), inner conductor +100°C (+212°F).

MECHANICAL CHARACTERISTICS

Weight	0.13 kg/m	(0.08 lb/ft)
Maximum pulling force	1650 N	(363 lb)
Minimum bending radius		
• Single bending	50 mm	(1.9 in)
• Repeated bending	95 mm	(3.7 in)
Operating temperature range	-55...+80°C	(-67...+176°F)
Crush resistance	2.0 kg/mm	(110 lb/in)
Bending moment	2.1 Nm	(1.5 lb-ft)
Recommended clamp spacing	1.0 m	(3.3 ft)

STANDARD DRUM

Cable type	Drum	Standard length m (ft)	Outer diam. (D) cm (in)	Outer width (W) cm (in)	Drum weight (empty) kg (lb)	Total weight kg (lb)	Drum freight volume m ³ (cu.ft)
RFA 3/8"	P6D	250 (820)	63 (25)	51 (20)	13 (29)	55 (117)	0.20 (7.06)

CODES FOR NKC CONNECTORS

Connector type	Code
7-16 male	NKC1038100
7-16 female	NKC1038200
N male	NKC1038300
N female	NKC1038400



Feeder cable

RFA 1/2''-50

Specifications

COAXIAL CABLE	
Type	Code
RFA 1/2''-50	NKRFA01200
RFA 1/2''-50 GHF	NKRFA01201
RFA 1/2''-50 BHF	NKRFA01202
RFA 1/2''-50 BHF (UL) CATVR	NKRFA01204

CONSTRUCTION

Inner conductor	Copper-clad aluminium wire	Ø 4.8 mm	(0.19 in)
Dielectric	Cellular polyethylene	Ø 12.1 mm	(0.48 in)
Outer conductor	Corrugated copper tube	Ø 13.9 mm	(0.55 in)
Jacket	See Jacketing Options table below	Ø 16.0 mm	(0.63 in)
Marking	Draka, cable type, manufacture week, year, batch number and meter mark		

ELECTRICAL CHARACTERISTICS at +20°C (+ 68°F)

Characteristic impedance	50 ± 1 Ω
Return loss 24 dB for 100 m (330ft) cable with NKC connectors for following frequency bands:	
• 380-500 MHz	
• 806-960 MHz	
• 1710-1880 MHz	
• 1900-2170 MHz	
• 3400-3600 MHz	
Other bands also available on request	
Bands according to customer's specifications	
Attenuation	See attenuation table
Velocity factor	0.88
Capacitance	76 pF/m (23pF/ft)
Maximum frequency	9800 MHz
Max power rating	See table
Peak RF voltage rating	1.80 kV
Peak power rating	31.8 kW
DC-resistance	
• Inner conductor	1.44 Ω/km (0.44 Ω /1000ft)
• Outer conductor	2.24 Ω/km (0.68 Ω /1000ft)

JACKETING OPTIONS							
Type	Jacket	IEC 60754 -1/-2 halogen free, non corrosive	IEC 61034 low smoke emission	IEC 60332-3-24 fire retardant	UV Retardancy	UL Rated	Min. installation temperature
RFA 1/2''-50	Black, halogen free polyethylene	yes	no	no	yes	no	-40°C (-40°F)
RFA 1/2''-50 GHF	Grey, halogen free fire retardant thermoplastic	yes	yes	yes	no	no	-20°C (-4°F)
RFA 1/2''-50 BHF	Black, halogen free fire retardant thermoplastic	yes	yes	yes	yes	no	-20°C (-4°F)
RFA 1/2''-50 BHF (UL) CATVR	Black, halogen free fire retardant UL Riser rated jacket	yes	yes	yes	yes	yes	-20°C (-4°F)

ATTENUATION			
Frequency MHz	Attenuation dB/100 m	Attenuation dB/100 ft	Power rating kW
10	0.665	(0.203)	12
30	1.16	(0.354)	6.9
50	1.51	(0.459)	5.3
88	2.01	(0.613)	4.0
100	2.15	(0.655)	3.7
108	2.24	(0.682)	3.6
174	2.86	(0.873)	2.8
200	3.08	(0.938)	2.6
300	3.81	(1.16)	2.1
400	4.43	(1.35)	1.8
450	4.72	(1.44)	1.7
500	4.99	(1.52)	1.6
512	5.06	(1.54)	1.6
600	5.50	(1.68)	1.4
700	5.98	(1.82)	1.3
800	6.43	(1.96)	1.2
850	6.64	(2.03)	1.2
890	6.81	(2.08)	1.2
900	6.85	(2.09)	1.2
950	7.06	(2.15)	1.1
960	7.10	(2.16)	1.1
1000	7.26	(2.21)	1.1
1200	8.02	(2.45)	0.98
1400	8.74	(2.66)	0.90
1600	9.41	(2.87)	0.83
1800	10.0	(3.06)	0.78
1900	10.4	(3.16)	0.76
2000	10.7	(3.25)	0.74
2200	11.3	(3.43)	0.70
2400	11.8	(3.60)	0.66
2600	12.4	(3.77)	0.63
2800	12.9	(3.94)	0.61
3000	13.4	(4.09)	0.58
3400	14.4	(4.40)	0.54
6000	20.2	(6.15)	0.39
8800	25.5	(7.77)	0.31

Attenuation values are typical at ambient temperature +20°C (+68°F). Power rating ambient temperature +40°C (+104°F), inner conductor +100°C (+212°F).

MECHANICAL CHARACTERISTICS

Weight	0.23 kg/m	(0.15 lb/ft)
Maximum pulling force	2550 N	(562 lb)
Minimum bending radius		
• Single bending	70 mm	(2.8 in)
• Repeated bending	120 mm	(4.7 in)
Operating temperature range	-55...+80°C	(-67...+176°F)
Crush resistance	2.0 kg/mm	(110 lb/in)
Bending moment	3.8 Nm	(2.8 lb-ft)
Recommended clamp spacing	1.0 m	(3.3 ft)

STANDARD DRUM

Cable type	Drum	Standard length		Outer diam. (D)		Outer width (W)		Drum weight (empty) kg (lb)	Total weight kg (lb)	Drum freight volume m ³ (cu.ft)
		m	(ft)	cm	(in)	cm	(in)			
RFA 1/2"	P11D	500	(1640)	114	(45)	51	(20)	45 (99)	176 (379)	0.66 (23.31)

CODES FOR NKC CONNECTORS

Connector type	Code
7-16 male	NKC1012100
7-16 female	NKC1012200
N male	NKC1012300
N female	NKC1012400
7-16 male Right angle	NKC1012500
N male Right angle	NKC1012600



Feeder cable

RFA 7/8''-50

Specifications

COAXIAL CABLE	
Type	Code
RFA 7/8''-50	NKRFA07800
RFA 7/8''-50 GHF	NKRFA07801
RFA 7/8''-50 BHF	NKRFA07802
RFA 7/8''-50 BHF (UL) CATVR	NKRFA07804

CONSTRUCTION

Inner conductor	Copper tube	Ø 9.4 mm	(0.37 in)
Dielectric	Cellular polyethylene	Ø 22.5 mm	(0.89 in)
Outer conductor	Corrugated copper tube	Ø 25.4 mm	(1.00 in)
Jacket	See Jacketing Options table below	Ø 28.0 mm	(1.10 in)
Marking	Draka, cable type, manufacture week, year, batch number and meter mark		

ELECTRICAL CHARACTERISTICS at +20°C (+ 68°F)

Characteristic impedance	50 ± 1 Ω
Return loss 24 dB for 100 m (330 ft) cable with NKC connectors for following frequency bands:	
• 380-500 MHz	
• 806-960 MHz	
• 1710-1880 MHz	
• 1900-2170 MHz	
• 3400-3600 MHz	
Other bands also available on request	
Bands according to customer's specifications	
Attenuation	See attenuation table
Velocity factor	0.90
Capacitance	74.2 pF/m (22.6 pF/ft)
Maximum frequency	5100 MHz
Max power rating	See table
Peak RF voltage rating	3.3 kV
Peak power rating	92.0 kW
DC-resistance	
• Inner conductor	1.28 Ω/km (0.39 Ω/1000 ft)
• Outer conductor	1.15 Ω/km (0.35 Ω/1000 ft)

JACKETING OPTIONS							
Type	Jacket	IEC 60754 -1/-2 halogen free, non corrosive	IEC 61034 low smoke emission	IEC 60332-3-24 fire retardant	UV Retardancy	UL Rated	Min. installation temperature
RFA 7/8''-50	Black, halogen free polyethylene (LDPE with HDPE skin)	yes	no	no	yes	no	-40°C (-40°F)
RFA 7/8''-50 GHF	Grey, halogen free fire retardant thermoplastic	yes	yes	yes	no	no	-20°C (-4°F)
RFA 7/8''-50 BHF	Black, halogen free fire retardant thermoplastic	yes	yes	yes	yes	no	-20°C (-4°F)
RFA 7/8''-50 BHF (UL) CATVR	Black, halogen free fire retardant UL Riser rated jacket	yes	yes	yes	yes	yes	-20°C (-4°F)

ATTENUATION			
Frequency MHz	Attenuation dB/100 m	Attenuation dB/100 ft	Power rating kW
10	0.346	(0.105)	27
30	0.603	(0.184)	16
50	0.782	(0.238)	12
88	1.04	(0.318)	8.9
100	1.12	(0.340)	8.4
108	1.16	(0.354)	8.0
174	1.48	(0.452)	6.3
200	1.60	(0.486)	5.8
300	1.97	(0.601)	4.7
400	2.29	(0.699)	4.0
450	2.44	(0.744)	3.8
500	2.58	(0.787)	3.6
512	2.61	(0.797)	3.5
600	2.84	(0.867)	3.2
700	3.09	(0.942)	3.0
800	3.32	(1.01)	2.8
850	3.43	(1.05)	2.7
890	3.52	(1.07)	2.6
900	3.54	(1.08)	2.6
950	3.64	(1.11)	2.5
960	3.66	(1.12)	2.5
1000	3.74	(1.14)	2.5
1200	4.14	(1.26)	2.2
1400	4.50	(1.37)	2.0
1600	4.84	(1.48)	1.9
1800	5.17	(1.58)	1.8
1900	5.33	(1.62)	1.7
2000	5.48	(1.67)	1.7
2200	5.78	(1.76)	1.6
2400	6.07	(1.85)	1.5
2600	6.35	(1.94)	1.4
2800	6.63	(2.02)	1.4
3000	6.89	(2.10)	1.3
3400	7.40	(2.26)	1.2
3500	7.53	(2.29)	1.2
3600	7.65	(2.33)	1.2
4000	8.13	(2.48)	1.1
5000	9.26	(2.82)	0.97

Attenuation values are typical at ambient temperature +20°C (+68°F). Power rating ambient temperature +40°C (+104°F), inner conductor +100°C (+212°F).

MECHANICAL CHARACTERISTICS

Weight	0.45 kg/m	(0.30 lb/ft)
Maximum pulling force	2500 N	(562 lb)
Minimum bending radius		
• Single bending	120 mm	(4.7 in)
• Repeated bending	240 mm	(9.4 in)
Operating temperature range	-55...+85°C	(-67...+185°F)
Crush resistance	1.6 kg/mm	(90 lb/in)
Bending moment	15.0 Nm	(11 lb-ft)
Recommended clamp spacing	1.0 m	(3.3 ft)

STANDARD DRUM

Cable type	Drum	Standard length		Outer diam. (D)		Outer width (W)		Drum weight (empty)		Total weight		Drum freight volume m ³ (cu.ft)	
		m	(ft)	cm	(in)	cm	(in)	kg	(lb)	kg	(lb)		
RFA 7/8"	P13G	500	(1640)	134	(52)	70	(28)	69	(152)	343	(760)	1.26	(44.50)

CODES FOR NKC CONNECTORS

Connector type	Code
7-16 male	NKC1078100
7-16 female	NKC1078200
7-16 Bulkhead female	NKC1078290
N male	NKC1078300
N female	NKC1078400
7-16 male Right angle	NKC1078500



Feeder cable

RFA 7/8''-50 AL

Specifications

COAXIAL CABLE	
Type	Code
RFA 7/8''-50 AL	NKRFAL07800
RFA 7/8''-50 AL GHF	NKRFAL07801
RFA 7/8''-50 AL BHF	NKRFAL07802
RFA 7/8''-50 AL BHF (UL) CATVR	NKRFAL07804

CONSTRUCTION

Inner conductor	Copper tube	Ø 9.4 mm	(0.37 in)
Dielectric	Cellular polyethylene	Ø 22.4 mm	(0.88 in)
Outer conductor	Corrugated aluminium tube	Ø 25.4 mm	(1.00 in)
Jacket	See Jacketing Options table below	Ø 28.0 mm	(1.10 in)
Marking	Draka, cable type, manufacture week, year, batch number and meter mark		

ELECTRICAL CHARACTERISTICS at +20°C (+ 68°F)

Characteristic impedance	50 ± 1 Ω
Return loss 24 dB for 100 m (330 ft) cable with NKC connectors for following frequency bands:	
• 380-500 MHz	
• 806-960 MHz	
• 1710-1880 MHz	
• 1900-2170 MHz	
• 3400-3600 MHz	
Other bands also available on request	
Bands according to customer's specifications	
Attenuation	See attenuation table
Velocity factor	0.90
Capacitance	73.5 pF/m (22.4 pF/ft)
Maximum frequency	5100 MHz
Max power rating	See table
Peak RF voltage rating	3.2 kV
Peak power rating	91.0 kW
DC-resistance	
• Inner conductor	1.30 Ω/km (0.40 Ω/1000 ft)
• Outer conductor	1.26 Ω/km (0.38 Ω/1000 ft)

JACKETING OPTIONS							
Type	Jacket	IEC 60754 -1/-2 halogen free, non corrosive	IEC 61034 low smoke emission	IEC 60332-3-24 fire retardant	UV Retardancy	UL Rated	Min. installation temperature
RFA 7/8''-50 AL	Black, halogen free polyethylene (LDPE with HDPE skin)	yes	no	no	yes	no	-40°C (-40°F)
RFA 7/8''-50 AL GHF	Grey, halogen free fire retardant thermoplastic	yes	yes	yes	no	no	-20°C (-4°F)
RFA 7/8''-50 AL BHF	Black, halogen free fire retardant thermoplastic	yes	yes	yes	yes	no	-20°C (-4°F)
RFA 7/8''-50 AL BHF (UL) CATVR	Black, halogen free fire retardant UL Riser rated jacket	yes	yes	yes	yes	yes	-20°C (-4°F)

ATTENUATION			
Frequency MHz	Attenuation dB/100 m	Attenuation dB/100 ft	Power rating kW
10	0.380	(0.116)	26
30	0.662	(0.202)	15
50	0.859	(0.262)	11
88	1.15	(0.350)	8.6
100	1.23	(0.373)	8.1
108	1.27	(0.388)	7.7
174	1.63	(0.497)	6.1
200	1.75	(0.534)	5.6
300	2.17	(0.660)	4.5
400	2.52	(0.768)	3.9
450	2.68	(0.818)	3.7
500	2.84	(0.865)	3.5
512	2.87	(0.876)	3.4
600	3.13	(0.953)	3.1
700	3.40	(1.04)	2.9
800	3.65	(1.11)	2.7
850	3.77	(1.15)	2.6
890	3.87	(1.18)	2.5
900	3.89	(1.19)	2.5
950	4.01	(1.22)	2.4
960	4.03	(1.23)	2.4
1000	4.12	(1.26)	2.4
1200	4.55	(1.39)	2.1
1400	4.95	(1.51)	2.0
1600	5.33	(1.62)	1.8
1800	5.69	(1.73)	1.7
1900	5.86	(1.79)	1.7
2000	6.03	(1.84)	1.6
2200	6.36	(1.94)	1.5
2400	6.68	(2.04)	1.5
2600	6.99	(2.13)	1.4
2800	7.29	(2.22)	1.3
3000	7.59	(2.31)	1.3
3400	8.15	(2.48)	1.2
3500	8.29	(2.53)	1.2
3600	8.42	(2.57)	1.2
4000	8.95	(2.73)	1.1
5000	10.2	(3.11)	0.9

Attenuation values are typical at ambient temperature +20°C (+68°F). Power rating ambient temperature +40°C (+104°F), inner conductor +100°C (+212°F).

MECHANICAL CHARACTERISTICS

Weight	0.37 kg/m	(0.25 lb/ft)
Maximum pulling force	1500 N	(331 lb)
Minimum bending radius		
• Single bending	120 mm	(4.7 in)
• Repeated bending	240 mm	(9.4 in)
Operating temperature range	-55...+80°C	(-67...+176°F)
Crush resistance	1.1 kg/mm	(62 lb/in)
Bending moment	18.0 Nm	(13 lb-ft)
Recommended clamp spacing	1.0 m	(3.3 ft)

STANDARD DRUM

Cable type	Drum	Standard length		Outer diam. (D)		Outer width (W)		Drum weight (empty)		Total weight		Drum freight volume m ³ (cu.ft)	
		m	(ft)	cm	(in)	cm	(in)	kg	(lb)	kg	(lb)		
RFA 7/8" AL	P13G	500	(1640)	134	(52)	70	(28)	69	(152)	285	(630)	1.26	(44.50)

CODES FOR NKC CONNECTORS

Connector type	Code
7-16 male	NKC1078100
7-16 female	NKC1078200
N male	NKC1078300
N female	NKC1078400



Feeder cable

RFA 1 1/4''-50

Specifications

COAXIAL CABLE	
Type	Code
RFA 1 1/4''-50	NKRFA11400
RFA 1 1/4''-50 GHF	NKRFA11401
RFA 1 1/4''-50 BHF	NKRFA11402

CONSTRUCTION

Inner conductor	Copper tube	Ø 13.0 mm	(0.51 in)
Dielectric	Cellular polyethylene	Ø 32.2 mm	(1.27 in)
Outer conductor	Corrugated copper tube	Ø 35.8 mm	(1.41 in)
Jacket	See Jacketing Options table below	Ø 39.0 mm	(1.54 in)
Marking	Draka, cable type, manufacture week, year, batch number and meter mark		

ELECTRICAL CHARACTERISTICS at +20°C (+ 68°F)

Characteristic impedance 50 ± 1 Ω

Return loss 24 dB for 100 m (330 ft) cable with NKC connectors for following frequency bands:

- 380-500 MHz
- 806-960 MHz
- 1710-1880 MHz
- 1900-2170 MHz

Other bands also available on request

Bands according to customer's specifications

Attenuation	See attenuation table
Velocity factor	0.88
Capacitance	75 pF/m (23 pF/ft)
Maximum frequency	3500 MHz
Max power rating	See table
Peak RF voltage rating	4.6 kV
Peak power rating	211.2 kW

DC-resistance	
• Inner conductor	0.74 Ω/km (0.22 Ω/1000 ft)
• Outer conductor	0.65 Ω/km (0.22 Ω/1000 ft)

JACKETING OPTIONS						
Type	Jacket	IEC 60754 -1/-2 halogen free, non corrosive	IEC 61034 low smoke emission	IEC 60332-3-24 fire retardant	UV Retardancy	Min. installation temperature
RFA 1 1/4''-50	Black, halogen free polyethylene (LDPE with HDPE skin)	yes	no	no	yes	-40°C (-40°F)
RFA 1 1/4''-50 GHF	Grey, halogen free fire retardant thermoplastic	yes	yes	yes	no	-5°C (+23°F)
RFA 1 1/4''-50 BHF	Black, halogen free fire retardant thermoplastic	yes	yes	yes	yes	-5°C (+23°F)

ATTENUATION			
Frequency MHz	Attenuation dB/100 m	Attenuation dB/100 ft	Power rating kW
10	0.250	(0.076)	41
30	0.439	(0.134)	23
50	0.571	(0.174)	18
88	0.766	(0.234)	13
100	0.819	(0.250)	12
108	0.853	(0.260)	12
174	1.10	(0.335)	9.2
200	1.18	(0.360)	8.6
300	1.47	(0.448)	6.8
400	1.72	(0.524)	5.8
450	1.83	(0.559)	5.5
500	1.94	(0.593)	5.2
512	1.97	(0.600)	5.1
600	2.15	(0.656)	4.7
700	2.34	(0.714)	4.3
800	2.53	(0.770)	3.9
850	2.62	(0.797)	3.8
890	2.68	(0.818)	3.7
900	2.70	(0.823)	3.7
950	2.79	(0.849)	3.6
960	2.80	(0.854)	3.6
1000	2.87	(0.874)	3.5
1200	3.18	(0.970)	3.1
1400	3.48	(1.06)	2.9
1600	3.76	(1.15)	2.6
1800	4.03	(1.23)	2.5
1900	4.17	(1.27)	2.4
2000	4.29	(1.31)	2.3
2200	4.54	(1.39)	2.2
2400	4.79	(1.46)	2.1
2600	5.03	(1.53)	1.9
2800	5.26	(1.60)	1.9
3000	5.48	(1.67)	1.8
3300	5.81	(1.77)	1.7

Attenuation values are typical at ambient temperature +20°C (+68°F). Power rating ambient temperature +40°C (+104°F), inner conductor +100°C (+212°F).

MECHANICAL CHARACTERISTICS

Weight	0.89 kg/m	(0.60 lb/ft)
Maximum pulling force	6050 N	(1340 lb)
Minimum bending radius		
• Single bending	200 mm	(8 in)
• Repeated bending	350 mm	(14 in)
Operating temperature range	-55...+80°C	(-67...+176°F)
Crush resistance	2.6 kg/mm	(146 lb/in)
Bending moment	48.7 Nm	(35.9 lb-ft)
Recommended clamp spacing	1.5 m	(5 ft)

STANDARD DRUM

Cable type	Drum	Standard length		Outer diam. (D)		Outer width (W)		Drum weight (empty) kg (lb)	Total weight		Drum freight volume m ³ (cu.ft)		
		m	(ft)	cm	(in)	cm	(in)		kg	(lb)			
RFA 1 1/4"	P20G	600	(1968)	204	(80)	70	(28)	155	(342)	735	(1621)	3.08	(108.76)

CODES FOR NKC CONNECTORS

Connector type	Code
7-16 male	NKC1114100
7-16 female	NKC1114200
7-16 Bulkhead female	NKC1114290
N male	NKC1114300
N female	NKC1114400



Feeder cable

RFA 1 5/8"-50

Specifications

COAXIAL CABLE	
Type	Code
RFA 1 5/8"-50	NKRFA15800
RFA 1 5/8"-50 GHF	NKRFA15801
RFA 1 5/8"-50 BHF	NKRFA15802

CONSTRUCTION

Inner conductor	Corrugated copper tube	Ø 17.6 mm	(0.69 in)
Dielectric	Cellular polyethylene	Ø 42.0 mm	(1.65 in)
Outer conductor	Corrugated copper tube	Ø 46.3 mm	(1.82 in)
Jacket	See Jacketing Options table below	Ø 50.0 mm	(1.97 in)
Marking	Draka, cable type, manufacture week, year, batch number and meter mark		

ELECTRICAL CHARACTERISTICS at +20°C (+ 68°F)

Characteristic impedance	50 ± 1 Ω
Return loss 24 dB for 100 m (330 ft) cable with NKC connectors for following frequency bands:	
• 380-500 MHz	
• 806-960 MHz	
• 1710-1880 MHz	
• 1900-2170 MHz	
Other bands also available on request	
Bands according to customer's specifications	
Attenuation	See attenuation table
Velocity factor	0.89
Capacitance	74 pF/m (22.6 pF/ft)
Maximum frequency	2800 MHz
Max power rating	See table
Peak RF voltage rating	5.7 kV
Peak power rating	314 kW
DC-resistance	
• Inner conductor	1.16 Ω/km (0.35 Ω/1000 ft)
• Outer conductor	0.43 Ω/km (0.13 Ω/1000 ft)

JACKETING OPTIONS						
Type	Jacket	IEC 60754 -1/-2 halogen free, non corrosive	IEC 61034 low smoke emission	IEC 60332-3-24 fire retardant	UV Retardancy	Min. installation temperature
RFA 1 5/8"-50	Black, halogen free polyethylene (LDPE with HDPE skin)	yes	no	no	yes	-20°C (-4°F)
RFA 1 5/8"-50 GHF	Grey, halogen free fire retardant thermoplastic	yes	yes	yes	no	-5°C (+23°F)
RFA 1 5/8"-50 BHF	Black, halogen free fire retardant thermoplastic	yes	yes	yes	yes	-5°C (+23°F)

ATTENUATION			
Frequency MHz	Attenuation dB/100 m	Attenuation dB/100 ft	Power rating kW
10	0.196	(0.060)	55
30	0.343	(0.105)	31
50	0.447	(0.136)	24
88	0.601	(0.183)	18
100	0.643	(0.196)	17
108	0.669	(0.204)	16
174	0.863	(0.263)	12
200	0.929	(0.283)	11
300	1.16	(0.353)	9.1
400	1.36	(0.413)	7.8
450	1.45	(0.441)	7.3
500	1.54	(0.468)	6.9
512	1.56	(0.474)	6.8
600	1.70	(0.518)	6.2
700	1.85	(0.565)	5.7
800	2.00	(0.610)	5.3
850	2.07	(0.631)	5.1
890	2.13	(0.648)	5.0
900	2.14	(0.652)	4.9
950	2.21	(0.673)	4.8
960	2.22	(0.677)	4.7
1000	2.27	(0.693)	4.6
1200	2.53	(0.770)	4.2
1400	2.77	(0.843)	3.8
1600	2.99	(0.913)	3.5
1800	3.21	(0.979)	3.3
1900	3.32	(1.01)	3.2
2000	3.42	(1.04)	3.1
2200	3.63	(1.11)	2.9
2400	3.82	(1.17)	2.7
2600	4.02	(1.22)	2.6
2800	4.20	(1.28)	2.5

Attenuation values are typical at ambient temperature +20°C (+68°F). Power rating ambient temperature +40°C (+104°F), inner conductor +100°C (+212°F).

MECHANICAL CHARACTERISTICS

Weight	1.16 kg/m	(0.78 lb/ft)
Maximum pulling force	3900 N	(860 lb)
Minimum bending radius		
• Single bending	200 mm	(7.9 in)
• Repeated bending	400 mm	(15.7 in)
Operating temperature range	-55...+80°C	(-67...+176°F)
Crush resistance	3.1 kg/mm	(173 lb/in)
Bending moment	45 Nm	(33)
Recommended clamp spacing	1.5 m	(5 ft)

STANDARD DRUM

Cable type	Drum	Standard length		Outer diam. (D)		Outer width (W)		Drum weight (empty)		Total weight		Drum freight volume m ³ (cu.ft)
		m	(ft)	cm	(in)	cm	(in)	kg	(lb)	kg	(lb)	
RFA 1 5/8"	P20G	400	(1312)	204	(80)	70	(28)	155	(342)	667	(1471)	3.08 (108.76)

CODES FOR NKC CONNECTORS

Connector type	Code
7-16 male	NKC1158100
7-16 female	NKC1158200
7-16 Bulkhead female	NKC1158290
N male	NKC1158300
N female	NKC1158400



Feeder cable

RFA 1 5/8"-50 AL

Specifications

COAXIAL CABLE	
Type	Code
RFA 1 5/8"-50 AL	NKRFAL15800
RFA 1 5/8"-50 AL GHF	NKRFAL15801
RFA 1 5/8"-50 AL BHF	NKRFAL15802

CONSTRUCTION

Inner conductor	Corrugated copper tube	Ø 17.5 mm	(0.69 in)
Dielectric	Cellular polyethylene	Ø 42.0 mm	(1.65 in)
Outer conductor	Corrugated aluminium tube	Ø 46.5 mm	(1.83 in)
Jacket	See Jacketing Options table below	Ø 50.0 mm	(1.97 in)
Marking	Draka, cable type, manufacture week, year, batch number and meter mark		

ELECTRICAL CHARACTERISTICS at +20°C (+ 68°F)

Characteristic impedance	50 ± 1 Ω
Return loss 24 dB for 100 m (330 ft) cable with NKC connectors for following frequency bands:	
• 380-500 MHz	
• 806-960 MHz	
• 1710-1880 MHz	
• 1900-2170 MHz	
Other bands also available on request	
Bands according to customer's specifications	
Attenuation	See attenuation table
Velocity factor	0.89
Capacitance	74 pF/m (22.6 pF/ft)
Maximum frequency	2800 MHz
Max power rating	See table
Peak RF voltage rating	5.6 kV
Peak power rating	310 kW
DC-resistance	
• Inner conductor	1.2 Ω/km (0.37 Ω/1000 ft)
• Outer conductor	0.6 Ω/km (0.18 Ω/1000 ft)

JACKETING OPTIONS						
Type	Jacket	IEC 60754 -1/-2 halogen free, non corrosive	IEC 61034 low smoke emission	IEC 60332-3-24 fire retardant	UV Retardancy	Min. installation temperature
RFA 1 5/8"-50 AL	Black, halogen free polyethylene (LDPE with HDPE skin)	yes	no	no	yes	-40°C (-40°F)
RFA 1 5/8"-50 AL GHF	Grey, halogen free fire retardant thermoplastic	yes	yes	yes	no	-5°C (+23°F)
RFA 1 5/8"-50 AL BHF	Black, halogen free fire retardant thermoplastic	yes	yes	yes	yes	-5°C (+23°F)

ATTENUATION			
Frequency MHz	Attenuation dB/100 m	Attenuation dB/100 ft	Power rating kW
10	0.212	(0.065)	47
30	0.372	(0.113)	27
50	0.485	(0.148)	20.5
88	0.65	(0.20)	15.3
100	0.70	(0.21)	14.3
108	0.73	(0.22)	13.7
174	0.93	(0.29)	10.6
200	1.01	(0.31)	9.8
300	1.25	(0.38)	7.8
400	1.47	(0.45)	6.7
450	1.56	(0.48)	6.2
500	1.66	(0.51)	5.9
512	1.68	(0.51)	5.8
600	1.84	(0.56)	5.3
700	2.00	(0.61)	4.8
800	2.16	(0.66)	4.5
850	2.23	(0.68)	4.3
890	2.29	(0.70)	4.2
900	2.31	(0.70)	4.2
950	2.38	(0.73)	4.0
960	2.39	(0.73)	4.0
1000	2.45	(0.75)	3.9
1200	2.72	(0.83)	3.5
1400	2.98	(0.91)	3.2
1600	3.22	(0.98)	2.9
1800	3.46	(1.05)	2.7
1900	3.57	(1.09)	2.7
2000	3.68	(1.12)	2.6
2200	3.90	(1.19)	2.4
2400	4.11	(1.25)	2.3
2600	4.31	(1.31)	2.2
2800	4.51	(1.37)	2.1

Attenuation values are typical at ambient temperature +20°C (+68°F). Power rating ambient temperature +40°C (+104°F), inner conductor +100°C (+212°F).

MECHANICAL CHARACTERISTICS

Weight	0.87 kg/m	(0.58 lb/ft)
Maximum pulling force	2000 N	(449 lb)
Minimum bending radius		
• Single bending	200 mm	(7.9 in)
• Repeated bending	380 mm	(15 in)
Operating temperature range	-55...+80°C	(-67...+176°F)
Crush resistance	1.8 kg/mm	(101 lb/in)
Bending moment	49.0 Nm	(11.2 lb-ft)
Recommended clamp spacing	1.5 m	(4.9 ft)

STANDARD DRUM

Cable type	Drum	Standard length		Outer diam. (D)		Outer width (W)		Drum weight (empty) kg (lb)	Total weight kg (lb)	Drum freight volume m ³ (cu.ft)
		m	(ft)	cm	(in)	cm	(in)			
RFA 1 5/8" AL	P20G	400	(1312)	204	(80)	70	(28)	155 (342)	667 (1471)	3.08 (108.76)

CODES FOR NKC CONNECTORS

Connector type	Code
7-16 male	NKC1158100
7-16 female	NKC1158200
N male	NKC1158300
N female	NKC1158400



Feeder cable

RFA 2 1/4"-50

Specifications

COAXIAL CABLE	
Type	Code
RFA 2 1/4"-50	NKRFA21400
RFA 2 1/4"-50 GHF	NKRFA21401
RFA 2 1/4"-50 BHF	NKRFA21402

CONSTRUCTION

Inner conductor	Corrugated copper tube	Ø 21.2 mm	(0.83 in)
Dielectric	Cellular polyethylene	Ø 52.0 mm	(2.05 in)
Outer conductor	Corrugated copper tube	Ø 55.9 mm	(2.20 in)
Jacket	See Jacketing Options table below	Ø 60.0 mm	(2.36 in)
Marking	Draka, cable type, manufacture week, year, batch number and meter mark		

ELECTRICAL CHARACTERISTICS at +20°C (+ 68°F)

Characteristic impedance	50 ± 1 Ω
Return loss 24 dB for 100 m (330 ft) cable with NKC connectors for following frequency bands:	
• 380-500 MHz	
• 806-960 MHz	
• 1710-1880 MHz	
• 1900-2170 MHz	
Other bands also available on request	
Bands according to customer's specifications	
Attenuation	See attenuation table
Velocity factor	0.88
Capacitance	75 pF/m (23 pF/ft)
Maximum frequency	2300 MHz
Max power rating	See table
Peak RF voltage rating	6.6 kV
Peak power rating	449.4 kW
DC-resistance	
• Inner conductor	0.55 Ω/km (0.17 Ω /1000 ft)
• Outer conductor	0.25 Ω/km (0.08 Ω /1000 ft)

JACKETING OPTIONS						
Type	Jacket	IEC 60754 -1/-2 halogen free, non corrosive	IEC 61034 low smoke emission	IEC 60332-3-24 fire retardant	UV Retardancy	Min. installation temperature
RFA 2 1/4"-50	Black, halogen free polyethylene	yes	no	no	yes	-20°C (-4°F)
RFA 2 1/4"-50 GHF	Grey, halogen free fire retardant thermoplastic	yes	yes	yes	no	-5°C (23°F)
RFA 2 1/4"-50 BHF	Black, halogen free fire retardant thermoplastic	yes	yes	yes	yes	-5°C (23°F)

ATTENUATION			
Frequency MHz	Attenuation dB/100 m	Attenuation dB/100 ft	Power rating kW
10	0.167	(0.051)	72
30	0.294	(0.090)	41
50	0.385	(0.117)	31
88	0.521	(0.159)	23
100	0.558	(0.170)	21
108	0.582	(0.177)	21
174	0.755	(0.230)	16
200	0.816	(0.249)	15
300	1.02	(0.312)	12
400	1.21	(0.368)	9.9
450	1.29	(0.394)	9.2
500	1.37	(0.419)	8.7
512	1.39	(0.425)	8.5
600	1.53	(0.466)	7.8
700	1.68	(0.511)	7.1
800	1.82	(0.553)	6.6
850	1.88	(0.574)	6.3
890	1.94	(0.590)	6.2
900	1.95	(0.594)	6.1
950	2.01	(0.614)	5.9
960	2.03	(0.618)	5.9
1000	2.08	(0.633)	5.7
1200	2.32	(0.708)	5.1
1400	2.56	(0.779)	4.7
1600	2.78	(0.848)	4.3
1800	3.00	(0.913)	4.0
1900	3.10	(0.945)	3.8
2000	3.21	(0.977)	3.7
2200	3.41	(1.04)	3.5

Attenuation values are typical at ambient temperature +20°C (+68°F). Power rating ambient temperature +40°C (+104°F), inner conductor +100°C (+212°F).

MECHANICAL CHARACTERISTICS

Weight	1.93 kg/m	(1.30 lb/ft)
Maximum pulling force	6950 N	(1550 lb)
Minimum bending radius		
• Single bending	240 mm	(9.4 in)
• Repeated bending	500 mm	(19.7 in)
Operating temperature range	-55...+80°C	(-67...+176°F)
Crush resistance	3.5 kg/mm	(196 lb/in)
Bending moment	94.5 Nm	(70 lb-ft)
Recommended clamp spacing	1.5 m	(5 ft)

STANDARD DRUM

Cable type	Drum	Standard length		Outer diam. (D)		Outer width (W)		Drum weight (empty) kg (lb)	Total weight kg (lb)	Drum freight volume m ³ (cu.ft)
		m	(ft)	cm	(in)	cm	(in)			
RFA 2 1/4"	P21Q	300	(984)	214	(84)	105	(41)	218 (481)	884 (1952)	5.40 (190.68)

CODES FOR NKC CONNECTORS

Connector type	Code
7-16 male	NKC1214100
7-16 female	NKC1214200
N male	NKC1214300
N female	NKC1214400

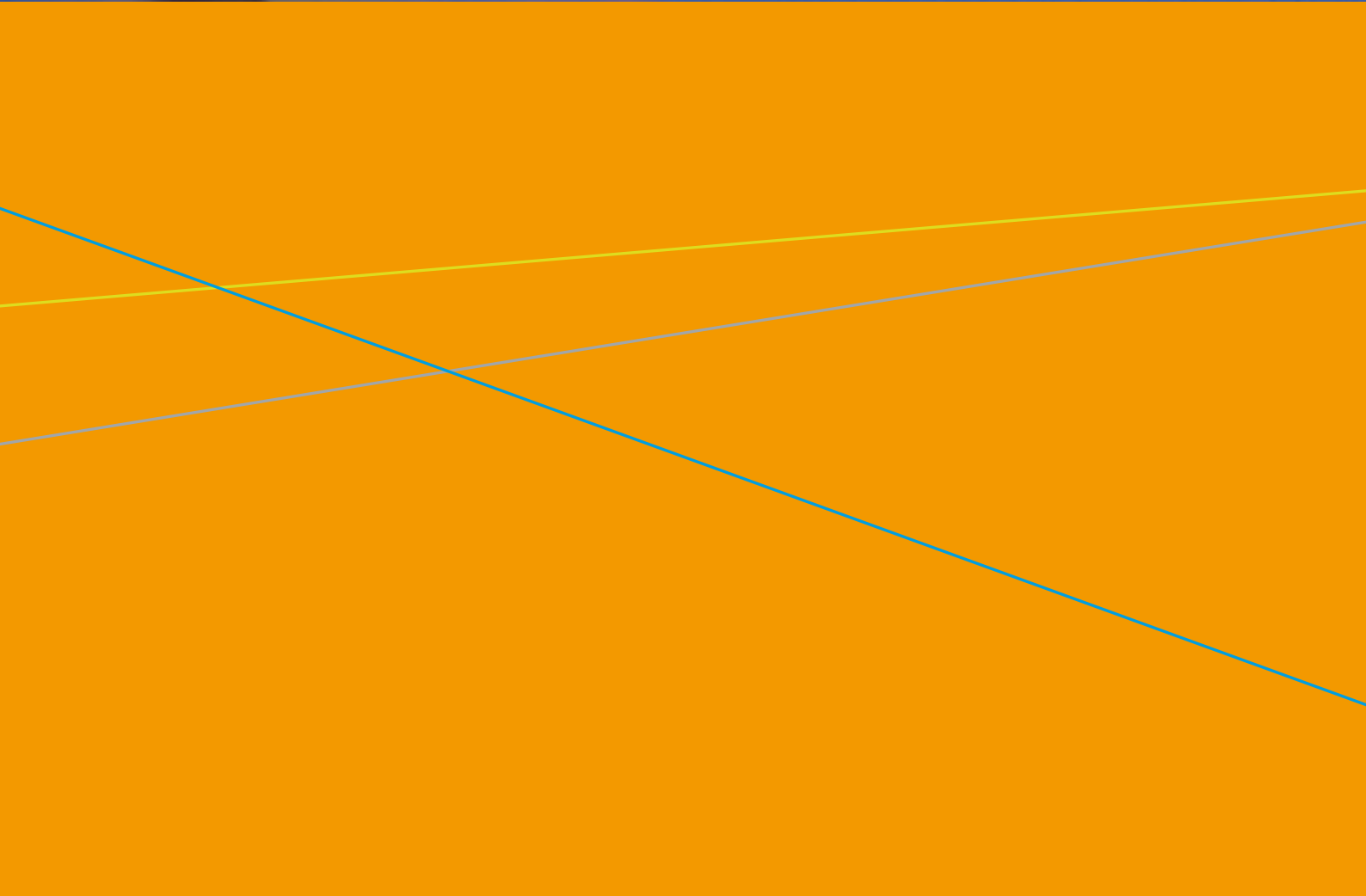

Superflexible and Extraflexible Cables

Draka superflexible RFF cables and extraflexible RFE cables offer the most convenient solution for installations in places where limited space requires small bending radius.

Our superflexible RFF cables are typically used as jumper cables. They have extremely high flexibility and crush resistance due to deep spiral corrugation. Our extraflexible RFE cables are perfect for applications where low attenuation must be combined with limited space installations.

High flexibility and low attenuation of our superflexible and extraflexible cables guarantee top performance in all circumstances.

Draka 50 Ohm Radio Frequency Cables

SUPERFLEXIBLE CABLES						
Type	Product code	Inner conductor diam. mm (in)	Outer conductor diam. mm (in)	Jacket diam. mm (in)	Standard length m (ft)	Standard drum type
RFF 1/4"-50	NKRFF01400	1.9 (0.07)	6.4 (0.25)	7.4 (0.29)	250 (820)	P5C
RFF 3/8"-50	NKRFF03800	2.6 (0.10)	9.0 (0.35)	10.1 (0.40)	250 (820)	P5C
RFF 1/2"-50	NKRFF01200	3.55 (0.14)	11.9 (0.47)	13.5 (0.53)	500 (1640)	P11D
RFE 7/8"-50	NKRFE07800	9.4 (0.37)	24.9 (0.98)	27.5 (1.08)	500 (1640)	P13G
RFE 1 1/4"-50	NKRFE11400	13.6 (0.53)	35.8 (1.41)	39.0 (1.53)	600 (1968)	P20G
RFE 1 5/8"-50	NKRFE15800	17.5 (0.69)	46.5 (1.83)	50.0 (1.97)	400 (1312)	P20G



Superflexible cable

RFF 1/4"-50

Specifications

COAXIAL CABLE	
Type	Code
RFF 1/4"-50	NKRFF01400
RFF 1/4"-50 GHF	NKRFF01401
RFF 1/4"-50 BHF	NKRFF01402
RFF 1/4"-50 BHF (UL) CATVR	NKRFF01404

CONSTRUCTION

Inner conductor	Copper wire	Ø 1.9 mm	(0.07 in)
Dielectric	Cellular polyethylene	Ø 4.8 mm	(0.19 in)
Outer conductor	Corrugated copper tube	Ø 6.4 mm	(0.25 in)
Jacket	See Jacketing Options table below	Ø 7.4 mm	(0.29 in)
Marking	Draka, cable type, manufacture week, year, batch number and meter mark		

ELECTRICAL CHARACTERISTICS at +20°C (+ 68°F)

Characteristic impedance	50 ± 2 Ω
Return loss 24 dB for 100 m (330 ft) cable with NKC connectors for following frequency bands:	
• 380-500 MHz	
• 806-960 MHz	
• 1710-1880 MHz	
• 1900-2170 MHz	
Other bands also available on request	
Bands according to customer's specifications	
Attenuation	See attenuation table
Velocity factor	0.83
Capacitance	78.2 pF/m (22.8 pF/ft)
Maximum frequency	21000 MHz
Max power rating	See table
Peak RF voltage rating	0.74 kV
Peak power rating	6.5 kW
DC-resistance	
• Inner conductor	6.2 Ω /km (1.89 Ω /1000 ft)
• Outer conductor	7.7 Ω /km (2.34 Ω /1000 ft)

JACKETING OPTIONS							
Type	Jacket	IEC 60754 -1/-2 halogen free, non corrosive	IEC 61034 low smoke emission	IEC 60332-3-24 fire retardant	UV Retardancy	UL Rated	Min. installation temperature
RFF 1/4"-50	Black, halogen free polyethylene	yes	no	no	yes	no	-40°C (-40°F)
RFF 1/4"-50 GHF	Grey, halogen free fire retardant thermoplastic	yes	yes	yes	no	no	-20°C (-4°F)
RFF 1/4"-50 BHF	Black, halogen free fire retardant thermoplastic	yes	yes	yes	yes	no	-20°C (-4°F)
RFF 1/4"-50 BHF (UL) CATVR	Black, halogen free fire retardant UL Riser rated jacket	yes	yes	yes	yes	yes	-20°C (-4°F)

ATTENUATION			
Frequency MHz	Attenuation dB/100 m	Attenuation dB/100 ft	Power rating kW
10	1.79	(0.547)	3.6
30	3.12	(0.950)	2.0
50	4.04	(1.230)	1.6
88	5.38	(1.64)	1.2
100	5.74	(1.75)	1.1
108	5.97	(1.82)	1.1
174	7.61	(2.32)	0.84
200	8.17	(2.49)	0.79
300	10.1	(3.07)	0.64
400	11.7	(3.56)	0.55
450	12.4	(3.78)	0.52
500	13.1	(3.99)	0.49
512	13.3	(4.04)	0.49
600	14.4	(4.39)	0.45
700	15.6	(4.75)	0.41
800	16.7	(5.10)	0.39
850	17.3	(5.26)	0.37
890	17.7	(5.39)	0.36
900	17.8	(5.42)	0.36
950	18.3	(5.58)	0.35
960	18.4	(5.61)	0.35
1000	18.8	(5.73)	0.34
1200	20.7	(6.30)	0.31
1400	22.4	(6.84)	0.29
1600	24.1	(7.34)	0.27
1800	25.6	(7.82)	0.25
1900	26.4	(8.05)	0.25
2000	27.1	(8.27)	0.24
2200	28.6	(8.70)	0.23
2400	29.9	(9.12)	0.22
2600	31.2	(9.52)	0.21
2800	32.5	(9.91)	0.20
3000	33.8	(10.3)	0.19
3400	36.1	(11.0)	0.18
4000	39.5	(12.0)	0.17
6000	49.4	(15.1)	0.13
8000	58.1	(17.7)	0.12
20400	100.0	(30.5)	0.07

Attenuation values are typical at ambient temperature +20°C (+68°F). Power rating ambient temperature +40°C (+104°F), inner conductor +100°C (+212°F).

MECHANICAL CHARACTERISTICS

Weight	0.09 kg/m	(0.06 lb/ft)
Maximum pulling force	780 N	(172 lb)
Minimum bending radius		
• Single bending	12.5 mm	(0.5 in)
• Repeated bending	25 mm	(1.0 in)
Operating temperature range	-55...+80°C	(-67...+176°F)
Crush resistance	2.3 kg/mm	(129 lb/in)
Bending moment	1.1 Nm	(0.8 lb-ft)
Recommended clamp spacing	0.5 m	(1.7 ft)

STANDARD DRUM

Cable type	Drum	Standard length		Outer diam. (D)		Outer width (W)		Drum weight (empty)		Total weight		Drum freight volume	
		m	(ft)	cm	(in)	cm	(in)	kg	(lb)	kg	(lb)	m ³	(cu.ft)
RFF 1/4"	P5C	250	(820)	53	(21)	50	(20)	9	(20)	37	(81)	0.14	(4.94)

CODES FOR NKC CONNECTORS

Connector type	Code
7-16 male	NKC2014120
7-16 female	NKC2014220
N male	NKC2014320
N female	NKC2014420
N male Right angle	NKC2014620



Superflexible cable

RFF 3/8"-50

Specifications

COAXIAL CABLE	
Type	Code
RFF 3/8"-50	NKRFF03800
RFF 3/8"-50 GHF	NKRFF03801
RFF 3/8"-50 BHF	NKRFF03802
RFF 3/8"-50 BHF (UL) CATVR	NKRFF03804

CONSTRUCTION

Inner conductor	Copper-clad aluminium wire	Ø 2.6 mm	(0.10 in)
Dielectric	Cellular polyethylene	Ø 6.5 mm	(0.26 in)
Outer conductor	Corrugated copper tube	Ø 9.0 mm	(0.35 in)
Jacket	See Jacketing Options table below	Ø 10.1 mm	(0.40 in)
Marking	Draka, cable type, manufacture week, year, batch number and meter mark		

ELECTRICAL CHARACTERISTICS at +20°C (+ 68°F)

Characteristic impedance	50 ± 1 Ω
Return loss 24 dB for 100 m (330 ft) cable with NKC connectors for following frequency bands:	
• 380-500 MHz	
• 806-960 MHz	
• 1710-1880 MHz	
• 1900-2170 MHz	
Other bands also available on request	
Bands according to customer's specifications	
Attenuation	See attenuation table
Velocity factor	0.81
Capacitance	82 pF/m (25.0 pF/ft)
Maximum frequency	15200 MHz
Max power rating	See table
Peak RF voltage rating	1.04 kV
Peak power rating	13.2 kW
DC-resistance	
• Inner conductor	5.1 Ω/km (1.55 Ω/1000 ft)
• Outer conductor	6.1 Ω/km (1.86 Ω/1000 ft)

JACKETING OPTIONS							
Type	Jacket	IEC 60754 -1/-2 halogen free, non corrosive	IEC 61034 low smoke emission	IEC 60332-3-24 fire retardant	UV Retardancy	UL Rated	Min. installation temperature
RFF 3/8"-50	Black, halogen free polyethylene	yes	no	no	yes	no	-40°C (-40°F)
RFF 3/8"-50 GHF	Grey, halogen free fire retardant thermoplastic	yes	yes	yes	no	no	-20°C (-4°F)
RFF 3/8"-50 BHF	Black, halogen free fire retardant thermoplastic	yes	yes	yes	yes	no	-20°C (-4°F)
RFF 3/8"-50 BHF (UL) CATVR	Black, halogen free fire retardant UL Riser rated jacket	yes	yes	yes	yes	yes	-20°C (-4°F)

ATTENUATION			
Frequency MHz	Attenuation dB/100 m	Attenuation dB/100 ft	Power rating kW
10	1.30	(0.397)	6.0
30	2.27	(0.692)	3.4
50	2.94	(0.897)	2.6
88	3.93	(1.20)	2.0
100	4.20	(1.28)	1.9
108	4.37	(1.33)	1.8
174	5.59	(1.71)	1.4
200	6.01	(1.83)	1.3
300	7.44	(2.27)	1.1
400	8.65	(2.64)	0.90
450	9.21	(2.81)	0.84
500	9.74	(2.97)	0.80
512	9.86	(3.01)	0.79
600	10.7	(3.27)	0.73
700	11.7	(3.55)	0.67
800	12.5	(3.82)	0.62
850	12.9	(3.95)	0.60
890	13.3	(4.05)	0.59
900	13.4	(4.07)	0.58
950	13.8	(4.19)	0.57
960	13.8	(4.22)	0.56
1000	14.1	(4.31)	0.55
1200	15.6	(4.76)	0.50
1400	17.0	(5.18)	0.46
1600	18.3	(5.58)	0.43
1800	19.6	(5.96)	0.40
1900	20.2	(6.14)	0.39
2000	20.7	(6.32)	0.38
2200	21.9	(6.67)	0.36
2400	23.0	(7.00)	0.34
2600	24.0	(7.33)	0.33
2800	25.1	(7.65)	0.31
3000	26.1	(7.95)	0.30
3400	28.0	(8.55)	0.28
4000	30.8	(9.39)	0.26
6000	39.1	(11.9)	0.20
8000	46.5	(14.2)	0.17
15200	69.4	(21.1)	0.12

Attenuation values are typical at ambient temperature +20°C (+68°F). Power rating ambient temperature +40°C (+104°F), inner conductor +100°C (+212°F).

MECHANICAL CHARACTERISTICS

Weight	0.12 kg/m	(0.08 lb/ft)
Maximum pulling force	600 N	(132 lb)
Minimum bending radius		
• Single bending	13 mm	(0.5 in)
• Repeated bending	25 mm	(1 in)
Operating temperature range	-55...+80°C	(-67...+176°F)
Crush resistance	3.3 kg/mm	(185 lb/in)
Bending moment	2.3 Nm	(1.7 lb-ft)
Recommended clamp spacing	1.0 m	(3.3 ft)

STANDARD DRUM

Cable type	Drum	Standard length		Outer diam. (D)		Outer width (W)		Drum weight (empty)		Total weight		Drum freight volume	
		m	(ft)	cm	(in)	cm	(in)	kg	(lb)	kg	(lb)	m ³	(cu.ft)
RFF 3/8"	P5C	250	(820)	53	(21)	50	(20)	9	(20)	45	(98)	0.14	(4.94)

CODES FOR NKC CONNECTORS

Connector type	Code
7-16 male	NKC2038100
7-16 female	NKC2038200
N male	NKC2038300
N female	NKC2038400
7-16 male Right angle	NKC2038500
N male Right angle	NKC2038600



Superflexible cable

RFF 1/2"-50

Specifications

COAXIAL CABLE	
Type	Code
RFF 1/2"-50	NKRFF01200
RFF 1/2"-50 GHF	NKRFF01201
RFF 1/2"-50 BHF	NKRFF01202
RFF 1/2"-50 BHF (UL) CATVR	NKRFF01204

CONSTRUCTION

Inner conductor	Copper-clad aluminium wire	Ø 3.55 mm	(0.14 in)
Dielectric	Cellular polyethylene	Ø 9.0 mm	(0.35 in)
Outer conductor	Corrugated copper tube	Ø 11.9 mm	(0.47 in)
Jacket	See Jacketing Options table below	Ø 13.5 mm	(0.53 in)
Marking	Draka, cable type, manufacture week, year, batch number and meter mark		

ELECTRICAL CHARACTERISTICS at +20°C (+ 68°F)

Characteristic impedance	50 ± 1 Ω
Return loss 24 dB for 100 m (330 ft) cable with NKC connectors for following frequency bands:	
• 380-500 MHz	
• 806-960 MHz	
• 1710-1880 MHz	
• 1900-2170 MHz	
Other bands also available on request	
Bands according to customer's specifications	
Attenuation	See attenuation table
Velocity factor	0.82
Capacitance	82 pF/m (25 pF/ft)
Maximum frequency	12 500 MHz
Max power rating	See table
Peak RF voltage rating	1.39 kV
Peak power rating	19.0 kW
DC-resistance	
• Inner conductor	2.57 Ω/km (0.78 Ω/1000 ft)
• Outer conductor	3.10 Ω/km (0.94 Ω/1000 ft)

JACKETING OPTIONS							
Type	Jacket	IEC 60754 -1/-2 halogen free, non corrosive	IEC 61034 low smoke emission	IEC 60332-3-24 fire retardant	UV Retardancy	UL Rated	Min. installation temperature
RFF 1/2"-50	Black, halogen free polyethylene	yes	no	no	yes	no	-40°C (-40°F)
RFF 1/2"-50 GHF	Grey, halogen free fire retardant thermoplastic	yes	yes	yes	no	no	-20°C (-4°F)
RFF 1/2"-50 BHF	Black, halogen free fire retardant thermoplastic	yes	yes	yes	yes	no	-20°C (-4°F)
RFF 1/2"-50 BHF (UL) CATVR	Black, halogen free fire retardant UL Riser rated jacket	yes	yes	yes	yes	yes	-20°C (-4°F)

ATTENUATION			
Frequency MHz	Attenuation dB/100 m	Attenuation dB/100 ft	Power rating kW
10	0.972	(0.296)	8.4
30	1.70	(0.517)	4.8
50	2.20	(0.671)	3.7
88	2.94	(0.896)	2.7
100	3.14	(0.957)	2.6
108	3.27	(0.996)	2.5
174	4.18	(1.28)	1.9
200	4.50	(1.37)	1.8
300	5.56	(1.70)	1.4
400	6.48	(1.97)	1.2
450	6.89	(2.10)	1.2
500	7.29	(2.22)	1.1
512	7.38	(2.25)	1.1
600	8.04	(2.45)	0.99
700	8.73	(2.66)	0.91
800	9.38	(2.86)	0.85
850	9.70	(2.96)	0.82
890	9.94	(3.03)	0.80
900	10.0	(3.05)	0.79
950	10.3	(3.14)	0.77
960	10.4	(3.16)	0.77
1000	10.6	(3.23)	0.75
1200	11.7	(3.57)	0.68
1400	12.7	(3.88)	0.62
1600	13.7	(4.18)	0.58
1800	14.7	(4.47)	0.54
1900	15.1	(4.60)	0.52
2000	15.5	(4.74)	0.51
2200	16.4	(5.00)	0.48
2400	17.2	(5.25)	0.46
2600	18.0	(5.50)	0.44
2800	18.8	(5.73)	0.42
3000	19.6	(5.97)	0.40
3400	21.0	(6.41)	0.37
4000	23.1	(7.05)	0.34
6000	29.4	(8.95)	0.27
8000	35.0	(10.7)	0.22
12400	45.9	(14.0)	0.17

Attenuation values are typical at ambient temperature +20°C (+68°F). Power rating ambient temperature +40°C (+104°F), inner conductor +100°C (+212°F).

MECHANICAL CHARACTERISTICS

Weight	0.19 kg/m	(0.13 lb/ft)
Maximum pulling force	900 N	(198 lb)
Minimum bending radius		
• Single bending	15 mm	(0.6 in)
• Repeated bending	30 mm	(1.2 in)
Operating temperature range	-55...+80°C	(-67...+176°F)
Crush resistance	3.4 kg/mm	(190 lb/in)
Bending moment	2.7 Nm	(2.0 lb-ft)
Recommended clamp spacing	1.0 m	(3.3 ft)

STANDARD DRUM

Cable type	Drum	Standard length		Outer diam. (D)		Outer width (W)		Drum weight (empty)		Total weight		Drum freight volume m ³ (cu.ft)	
		m	(ft)	cm	(in)	cm	(in)	kg	(lb)	kg	(lb)		
RFF 1/2"	P11D	500	(1640)	114	(45)	51	(20)	45	(99)	156	(346)	0.66	(23.31)

CODES FOR NKC CONNECTORS

Connector type	Code
7-16 male	NKC2012100
7-16 female	NKC2012200
N male	NKC2012300
N female	NKC2012400
7-16 male Right angle	NKC2012500
N male Right angle	NKC2012600



Extraflexible cable

RFE 7/8"-50

Specifications

COAXIAL CABLE	
Type	Code
RFE 7/8"-50	NKRFE07800
RFE 7/8"-50 GHF	NKRFE07801
RFE 7/8"-50 BHF	NKRFE07802
RFE 7/8"-50 BHF (UL) CATVR	NKRFE07804

CONSTRUCTION

Inner conductor	Corrugated copper tube	Ø 9.4 mm	(0.37 in)
Dielectric	Cellular polyethylene	Ø 21.7 mm	(0.85 in)
Outer conductor	Corrugated copper tube	Ø 24.9 mm	(0.98 in)
Jacket	See Jacketing Options table below	Ø 27.5 mm	(1.08 in)
Marking	Draka, cable type, manufacture week, year, batch number and meter mark		

ELECTRICAL CHARACTERISTICS at +20°C (+ 68°F)

Characteristic impedance	50 ± 1 Ω
Return loss 24 dB for 100 m (330 ft) cable with NKC connectors for following frequency bands:	
• 380-500 MHz	
• 806-960 MHz	
• 1710-1880 MHz	
• 1900-2170 MHz	
Other bands also available on request	
Bands according to customer's specifications	
Attenuation	See attenuation table
Velocity factor	0.88
Capacitance	74.3 pF/m (22.7 pF/ft)
Maximum frequency	5200 MHz
Max power rating	See table
Peak RF voltage rating	2.8 kV
Peak power rating	91.3 kW
DC-resistance	
• Inner conductor	2.50 Ω/km (0.76 Ω/1000 ft)
• Outer conductor	1.07 Ω/km (0.32 Ω/1000 ft)

JACKETING OPTIONS

Type	Jacket	IEC 60754 -1/-2 halogen free, non corrosive	IEC 61034 low smoke emission	IEC 60332-3-24 fire retardant	UV Retardancy	UL Rated	Min. installation temperature
RFE 7/8"-50	Black, halogen free polyethylene	yes	no	no	yes	no	-40°C (-40°F)
RFE 7/8"-50 GHF	Grey, halogen free fire retardant thermoplastic	yes	yes	yes	no	no	-20°C (-4°F)
RFE 7/8"-50 BHF	Black, halogen free fire retardant thermoplastic	yes	yes	yes	yes	no	-20°C (-4°F)
RFE 7/8"-50 BHF (UL) CATVR	Black, halogen free fire retardant UL Riser rated jacket	yes	yes	yes	yes	yes	-20°C (-4°F)

ATTENUATION

Frequency MHz	Attenuation dB/100 m	Attenuation dB/100 ft	Power rating kW
10	0.380	(0.116)	24
30	0.663	(0.202)	14
50	0.861	(0.263)	11
88	1.15	(0.351)	8.0
100	1.23	(0.375)	7.5
108	1.28	(0.391)	7.2
174	1.64	(0.501)	5.6
200	1.77	(0.539)	5.2
300	2.19	(0.668)	4.2
400	2.55	(0.778)	3.6
450	2.72	(0.829)	3.4
500	2.88	(0.878)	3.2
512	2.92	(0.889)	3.1
600	3.18	(0.969)	2.9
700	3.46	(1.05)	2.6
800	3.72	(1.13)	2.5
850	3.84	(1.17)	2.4
890	3.94	(1.20)	2.3
900	3.97	(1.21)	2.3
950	4.09	(1.25)	2.2
960	4.11	(1.25)	2.2
1000	4.21	(1.28)	2.2
1200	4.65	(1.42)	2.0
1400	5.07	(1.55)	1.8
1600	5.47	(1.67)	1.7
1800	5.85	(1.78)	1.6
1900	6.03	(1.84)	1.5
2000	6.21	(1.89)	1.5
2200	6.56	(2.00)	1.4
2400	6.90	(2.10)	1.3
2600	7.23	(2.20)	1.3
2800	7.55	(2.30)	1.2
3000	7.86	(2.40)	1.2
3400	8.46	(2.58)	1.1
4000	9.32	(2.84)	0.98
5000	10.7	(3.25)	0.86

Attenuation values are typical at ambient temperature +20°C (+68°F). Power rating ambient temperature +40°C (+104°F), inner conductor +100°C (+212°F).

MECHANICAL CHARACTERISTICS

Weight	0.43 kg/m	(0.29 lb/ft)
Maximum pulling force	1500 N	(330 lb)
Minimum bending radius		
• Single bending	90 mm	(3.5 in)
• Repeated bending	120 mm	(4.7 in)
Operating temperature range	-55...+80°C	(-67...+176°F)
Crush resistance	1.6 kg/mm	(90 lb/in)
Bending moment	15.7 Nm	(11.6 lb-ft)
Recommended clamp spacing	1.0 m	(3.3 ft)

STANDARD DRUM

Cable type	Drum	Standard length		Outer diam. (D)		Outer width (W)		Drum weight (empty)		Total weight		Drum freight volume	
		m	(ft)	cm	(in)	cm	(in)	kg	(lb)	kg	(lb)	m ³	(cu.ft)
RFE 7/8"	P13G	500	(1640)	134	(52)	70	(28)	69	(152)	315	(696)	1.24	(44.50)

CODES FOR NKC CONNECTORS

Connector type	Code
7-16 male	NKC1078100
7-16 female	NKC1078200
7-16 Bulkhead female	NKC1078290
N male	NKC1078300
N female	NKC1078400
7-16 male Right angle	NKC1078500



Extraflexible cable

RFE 1 1/4"-50

Specifications

COAXIAL CABLE	
Type	Code
RFE 1 1/4"-50	NKRFE11400
RFE 1 1/4"-50 GHF	NKRFE11401
RFE 1 1/4"-50 BHF	NKRFE11402

CONSTRUCTION

Inner conductor	Corrugated copper tube	Ø 13.6 mm	(0.53 in)
Dielectric	Cellular polyethylene	Ø 32.2 mm	(1.27 in)
Outer conductor	Corrugated copper tube	Ø 35.8 mm	(1.41 in)
Jacket	See Jacketing Options table below	Ø 39.0 mm	(1.53 in)
Marking	Draka, cable type, manufacture week, year, batch number and meter mark		

ELECTRICAL CHARACTERISTICS at +20°C (+ 68°F)

Characteristic impedance	50 ± 1 Ω
Return loss 24 dB for 100 m (330 ft) cable with NKC connectors for following frequency bands:	
• 380-500 MHz	
• 806-960 MHz	
• 1710-1880 MHz	
• 1900-2170 MHz	
Other bands also available on request	
Bands according to customer's specifications	
Attenuation	See attenuation table
Velocity factor	0.88
Capacitance	74.6 pF/m (22.7 pF/ft)
Maximum frequency	3700 MHz
Max power rating	See table
Peak RF voltage rating	4.5 kV
Peak power rating	187.2 kW
DC-resistance	
• Inner conductor	1.24 Ω/km (0.38 Ω/1000 ft)
• Outer conductor	0.59 Ω/km (0.18 Ω/1000 ft)

JACKETING OPTIONS						
Type	Jacket	IEC 60754 -1/-2 halogen free, non corrosive	IEC 61034 low smoke emission	IEC 60332-3-24 fire retardant	UV Retardancy	Min. installation temperature
RFE 1 1/4"-50	Black, halogen free polyethylene (LDPE with HDPE skin)	yes	no	no	yes	-40°C (-40°F)
RFE 1 1/4"-50 GHF	Grey, halogen free fire retardant thermoplastic	yes	yes	yes	no	-5°C (+23°F)
RFE 1 1/4"-50 BHF	Black, halogen free fire retardant thermoplastic	yes	yes	yes	yes	-5°C (+23°F)

ATTENUATION			
Frequency MHz	Attenuation dB/100 m	Attenuation dB/100 ft	Power rating kW
10	0.256	(0.078)	38
30	0.449	(0.137)	22
50	0.584	(0.178)	17
88	0.784	(0.239)	12
100	0.838	(0.256)	12
108	0.873	(0.266)	11
174	1.12	(0.343)	8.6
200	1.21	(0.369)	8.0
300	1.51	(0.459)	6.4
400	1.76	(0.537)	5.5
450	1.88	(0.537)	5.1
500	1.99	(0.607)	4.8
512	2.02	(0.615)	4.8
600	2.21	(0.672)	4.4
700	2.40	(0.733)	4.0
800	2.59	(0.790)	3.7
850	2.68	(0.817)	3.6
890	2.75	(0.839)	3.5
900	2.77	(0.844)	3.5
950	2.86	(0.871)	3.4
960	2.87	(0.876)	3.4
1000	2.94	(0.897)	3.3
1200	3.27	(0.996)	3.0
1400	3.57	(1.09)	2.7
1600	3.86	(1.18)	2.5
1800	4.14	(1.26)	2.3
1900	4.28	(1.30)	2.2
2000	4.41	(1.34)	2.2
2200	4.67	(1.42)	2.1
2400	4.92	(1.50)	2.0
2600	5.17	(1.57)	1.9
2800	5.40	(1.65)	1.8
3000	5.64	(1.72)	1.7
3300	5.98	(1.82)	1.6

Attenuation values are typical at ambient temperature +20°C (+68°F). Power rating ambient temperature +40°C (+104°F), inner conductor +100°C (+212°F).

MECHANICAL CHARACTERISTICS

Weight	0.79 kg/m	(0.53 lb/ft)
Maximum pulling force	5100 N	(1124 lb)
Minimum bending radius		
• Single bending	120 mm	(4.7 in)
• Repeated bending	220 mm	(8.7 in)
Operating temperature range	-55...+80°C	(-67...+176°F)
Crush resistance	2.3 kg/mm	(129 lb/in)
Bending moment	30.2 Nm	(22.3 lb-ft)
Recommended clamp distance	1.5 m	(5 ft)

STANDARD DRUM

Cable type	Drum	Standard length		Outer diam. (D)		Outer width (W)		Drum weight (empty)		Total weight		Drum freight volume	
		m	(ft)	cm	(in)	cm	(in)	kg	(lb)	kg	(lb)	m ³	(cu.ft)
RFE 1 1/4"	P20G	600	(1968)	204	(80)	70	(28)	155	(342)	675	(1486)	3.08	(108.76)

CODES FOR NKC CONNECTORS

Connector type	Code
7-16 male	NKC1114100
7-16 female	NKC1114200
7-16 Bulkhead female	NKC1114290
N male	NKC1114300
N female	NKC1114400



Extraflexible cable

RFE 1 5/8"-50

Specifications

COAXIAL CABLE	
Type	Code
RFE 1 5/8"-50	NKRFE15800
RFE 1 5/8"-50 GHF	NKRFE15801
RFE 1 5/8"-50 BHF	NKRFE15802

CONSTRUCTION

Inner conductor	Corrugated copper tube	Ø 17.5 mm	(0.69 in)
Dielectric	Cellular polyethylene	Ø 42.0 mm	(1.65 in)
Outer conductor	Corrugated copper tube	Ø 46.5 mm	(1.83 in)
Jacket	See Jacketing Options table below	Ø 50.0 mm	(1.97 in)
Marking	Draka, cable type, manufacture week, year, batch number and meter mark		

ELECTRICAL CHARACTERISTICS at +20°C (+ 68°F)

Characteristic impedance	50 ± 1
Return loss 24 dB for 100 m (330 ft) cable with NKC connectors for following frequency bands:	
• 380-500 MHz	
• 806-960 MHz	
• 1710-1880 MHz	
• 1900-2170 MHz	
Other bands also available on request	
Bands according to customer's specifications	
Attenuation	See attenuation table
Velocity factor	0.88
Capacitance	73.8 pF/m (23 pF/ft)
Maximum frequency	2800 MHz
Max power rating	See table
Peak RF voltage rating	5.0 kV
Peak power rating	284.0 kW
DC-resistance	
• Inner conductor	1.23 Ω/km (0.37 Ω/1000 ft)
• Outer conductor	0.38 Ω/km (0.12 Ω/1000 ft)

JACKETING OPTIONS

Type	Jacket	IEC 60754 -1/-2 halogen free, non corrosive	IEC 61034 low smoke emission	IEC 60332-3-24 fire retardant	UV Retardancy	Min. installation temperature
RFE 1 5/8"-50	Black, halogen free polyethylene	yes	no	no	yes	-20°C (-4°F)
RFE 1 5/8"-50 GHF	Grey, halogen free fire retardant thermoplastic	yes	yes	yes	no	-5°C (+23°F)
RFE 1 5/8"-50 BHF	Black, halogen free fire retardant thermoplastic	yes	yes	yes	yes	-5°C (+23°F)

ATTENUATION			
Frequency MHz	Attenuation dB/100 m	Attenuation dB/100 ft	Power rating kW
10	0.198	(0.060)	55
30	0.349	(0.106)	31
50	0.456	(0.139)	24
88	0.615	(0.187)	18
100	0.659	(0.201)	16
108	0.686	(0.209)	16
174	0.889	(0.271)	12
200	0.959	(0.292)	11
300	1.20	(0.366)	9.0
400	1.41	(0.430)	7.7
450	1.51	(0.460)	7.2
500	1.60	(0.489)	6.7
512	1.63	(0.496)	6.6
600	1.78	(0.543)	6.0
700	1.95	(0.594)	5.5
800	2.11	(0.643)	5.1
850	2.19	(0.666)	4.9
890	2.25	(0.685)	4.8
900	2.26	(0.689)	4.8
950	2.34	(0.712)	4.6
960	2.35	(0.716)	4.6
1000	2.41	(0.734)	4.5
1200	2.69	(0.819)	4.0
1400	2.95	(0.900)	3.6
1600	3.21	(0.977)	3.4
1800	3.45	(1.05)	3.1
1900	3.57	(1.09)	3.0
2000	3.69	(1.12)	2.9
2200	3.91	(1.19)	2.7
2400	4.14	(1.26)	2.6
2600	4.35	(1.33)	2.5

Attenuation values are typical at ambient temperature +20°C (+68°F). Power rating ambient temperature +40°C (+104°F), inner conductor +100°C (+212°F).

MECHANICAL CHARACTERISTICS

Weight	1.19 kg/m	(0.80 lb/ft)
Maximum pulling force	2700 N	(595 lb)
Minimum bending radius		
• Single bending	200 mm	(7.9 in)
• Repeated bending	350 mm	(13.8 in)
Operating temperature range	-55...+80°C	(-67...+176°F)
Crush resistance	2.1 kg/mm	(118 lb/in)
Bending moment	48.1 Nm	(35.5 lb-ft)
Recommended clamp distance	1.0 m	(3.3 ft)

STANDARD DRUM

Cable type	Drum	Standard length		Outer diam. (D)		Outer width (W)		Drum weight (empty) kg (lb)	Total weight		Drum freight volume m ³ (cu.ft)		
		m	(ft)	cm	(in)	cm	(in)		kg	(lb)			
RFE 1 5/8"	P20G	400	(1312)	204	(80)	70	(28)	155	(342)	677	(1492)	3.08	(108.76)

CODES FOR NKC CONNECTORS

Connector type	Code
7-16 male	NKC1158100
7-16 female	NKC1158200
7-16 Bulkhead female	NKC1158290
N male	NKC1158300
N female	NKC1158400



Coaxial Antennas

Draka coaxial antennas include two product families: RFX / RF2X and RFXT. RFX and RF2X cables are the best choice for multi- and broadband systems. RFXT cables are ideal when certain selected frequencies are required; the performance of RFXT cables is optimized for the respective frequency bands. Our coaxial antennas provide a reliable way to build indoor coverage network in buildings and in tunnels.

RFX and RF2X cables are coupled mode cables with a corrugated and milled outer conductor. RFX cables have slots in one line on the outer

conductor and RF2X have slots in two lines on the outer conductor. These cables are also available with a suspension wire: RFXK and RF2XK. RFXT cables are radiating mode cables with a periodically slotted and overlapped copper tape outer conductor.

The most important electrical characteristics of coaxial antennas are longitudinal attenuation and coupling loss. The excellent electrical performance of our RFX, RF2X and RFXT cables is achieved by continuous development work and an extensive test program.

Draka 50 Ohm Radio Frequency Cables

COAXIAL ANTENNAS						
Type	Product code	Inner conductor diam. mm (in)	Outer conductor diam. mm (in)	Jacket diam. mm (in)	Standard length m (ft)	Standard drum type
RFX 1/2"-50	NKRFX01200	4.8 (0.19)	13.9 (0.55)	16.0 (0.63)	500 (1640)	P11D
RFX 7/8"-50	NKRFX07800	9.3 (0.37)	25.2 (0.99)	27.8 (1.09)	500 (1640)	P13G
RFX 1 1/4"-50	NKRFX11400	13.0 (0.51)	35.8 (1.41)	39.0 (1.54)	600 (1968)	P20G
RFX 1 5/8"-50	NKRFX15800	17.6 (0.69)	46.3 (1.82)	50.0 (1.97)	400 (1312)	P20G
RFXT 7/8"-50	NKRFX07806	9.0 (0.35)	23.5 (0.93)	28.7 (1.13)	500 (1640)	P21G
RFXT 1 1/4"-50	NKRFX11406	12.8 (0.50)	32.8 (1.29)	38.8 (1.53)	500 (1640)	P19Q



Coaxial Antennas

RFX 1/2"-50

RF2X 1/2"-50

Specifications

COAXIAL CABLE	
Type	Code
RFX 1/2"-50	NKRFX01200
RFX 1/2"-50 GHF	NKRFX01201
RFX 1/2"-50 BHF	NKRFX01202
RF2X 1/2"-50	NKRFX2X01200
RF2X 1/2"-50 GHF	NKRFX2X01201
RF2X 1/2"-50 BHF	NKRFX2X01202

CONSTRUCTION

Inner conductor	Copper-clad aluminium wire	Ø 4.8 mm	(0.19 in)
Dielectric	Cellular polyethylene	Ø 12.1 mm	(0.48 in)
Outer conductor	Corrugated slotted copper tube	Ø 13.9 mm	(0.55 in)
Jacket	See Jacketing Options table below	Ø 16.0 mm	(0.63 in)
Marking	Draka, cable type, manufacture week, year, batch number and meter mark		

MECHANICAL CHARACTERISTICS

Weight	0.22 kg/m	(0.15 lb/ft)
Maximum pulling force	2550 N	(562 lb)
Minimum single bending radius	120 mm	(4.7 in)
Operating temperature range	-55...+80°C	(-67...+176°F)
Recommended clamp spacing	1.0 m	(3.3 ft)

JACKETING OPTIONS						
Type	Jacket	IEC 60754 -1/-2 halogen free, non corrosive	IEC 61034 low smoke emission	IEC 60332-1 fire retardant	UV Retardancy	Min. installation temperature
RFX 1/2"-50 RF2X 1/2"-50	Black, halogen free polyethylene	yes	no	no	yes	-40°C (-40°F)
RFX 1/2"-50 GHF RF2X 1/2"-50 GHF	Grey, halogen free fire retardant thermoplastic	yes	no	yes	no	-20°C (-4°F)
RFX 1/2"-50 BHF RF2X 1/2"-50 BHF	Black, halogen free fire retardant thermoplastic	yes	no	yes	yes	-20°C (-4°F)
RFX 1/2"-50 MBHF RF2X 1/2"-50 MBHF	Black, halogen free fire retardant thermoplastic with mica tape	yes	yes	yes	yes	-20°C (-4°F)

ELECTRICAL CHARACTERISTICS at +20°C (+ 68°F)

Characteristic impedance	50 ± 2 Ω	
Typical return loss (VSWR) on effective frequency range	18 dB	(1.29)
Velocity factor	0.88	
Capacitance	76 pF/m	(23 pF/ft)
Maximum frequency	9800 MHz	
DC-resistance		
• Inner conductor	1.44 Ω/km	(0.44 Ω/1000 ft)
• Outer conductor	2.24 Ω/km	(0.68 Ω/1000 ft)

**ATTENUATION
(measured acc. to IEC 61196-4 free space method)****RFX 1/2"-50**

at 75 MHz	2.0 dB/100 m	(0.61 dB/100 ft)
at 150 MHz	2.8 dB/100 m	(0.85 dB/100 ft)
at 450 MHz	5.0 dB/100 m	(1.52 dB/100 ft)
at 900 MHz	7.3 dB/100 m	(2.23 dB/100 ft)
at 1.8 GHz	10.8 dB/100 m	(3.29 dB/100 ft)
at 2.1 GHz	11.7 dB/100 m	(3.57 dB/100 ft)
at 2.4 GHz	12.7 dB/100 m	(3.87 dB/100 ft)

RF2X 1/2"-50

at 75 MHz	2.2 dB/100 m	(0.67 dB/100 ft)
at 150 MHz	3.1 dB/100 m	(0.94 dB/100 ft)
at 450 MHz	5.7 dB/100 m	(1.74 dB/100 ft)
at 900 MHz	8.4 dB/100 m	(2.56 dB/100 ft)
at 1.8 GHz	12.7 dB/100 m	(3.87 dB/100 ft)
at 2.1 GHz	14.0 dB/100 m	(4.27 dB/100 ft)
at 2.4 GHz	15.1 dB/100 m	(4.60 dB/100 ft)

**COUPLING LOSS
(measured acc. to IEC 61196-4 free space method)****RFX 1/2"-50** 50% value 95% value

at 75 MHz	63 dB	69 dB
at 150 MHz	68 dB	74 dB
at 450 MHz	76 dB	82 dB
at 900 MHz	78 dB	83 dB
at 1.8 GHz	79 dB	86 dB
at 2.1 GHz	80 dB	88 dB
at 2.4 GHz	81 dB	91 dB

RF2X 1/2"-50 50% value 95% value

at 75 MHz	57 dB	64 dB
at 150 MHz	63 dB	68 dB
at 450 MHz	69 dB	74 dB
at 900 MHz	71 dB	78 dB
at 1.8 GHz	77 dB	83 dB
at 2.1 GHz	74 dB	81 dB
at 2.4 GHz	76 dB	85 dB

STANDARD DRUM

Cable type	Drum	Standard length		Outer diam. (D)		Outer width (W)		Drum weight (empty) kg (lb)	Total weight kg (lb)	Drum freight volume m ³ (cu.ft)
		m	(ft)	cm	(in)	cm	(in)			
RFX 1/2"	P11D	500	(1640)	114	(45)	51	(20)	45 (99)	170 (375)	0.66 (23.31)

CODES FOR NKC CONNECTORS

Connector type	Code
7-16 male	NKC1012100
7-16 female	NKC1012200
N male	NKC1012300
N female	NKC1012400
7-16 male Right angle	NKC1012500
N male Right angle	NKC1012600



Coaxial Antennas

RFX 7/8"-50

RF2X 7/8"-50

Specifications

COAXIAL CABLE	
Type	Code
RFX 7/8"-50	NKRFX07800
RFX 7/8"-50 GHF	NKRFX07801
RFX 7/8"-50 BHF	NKRFX07802
RF2X 7/8"-50	NKRFX2X07800
RF2X 7/8"-50 GHF	NKRFX2X07801
RF2X 7/8"-50 BHF	NKRFX2X07802

CONSTRUCTION

Inner conductor	Copper tube	Ø 9.3 mm	(0.37 in)
Dielectric	Cellular polyethylene	Ø 22.0 mm	(0.86 in)
Outer conductor	Corrugated slotted copper tube	Ø 25.2 mm	(0.99 in)
Jacket	See Jacketing Options table below	Ø 27.8 mm	(1.09 in)
Marking	Draka, cable type, manufacture week, year, batch number and meter mark		

MECHANICAL CHARACTERISTICS

Weight	0.46 kg/m	(0.31 lb/ft)
Maximum pulling force	2800 N	(617 lb)
Minimum single bending radius	240 mm	(9.4 in)
Operating temperature range	-55...+80°C	(-67...+176°F)
Recommended clamp spacing	1.0 m	(3.3 ft)

JACKETING OPTIONS						
Type	Jacket	IEC 60754 -1/-2 halogen free, non corrosive	IEC 61034 low smoke emission	IEC 60332-3-24 fire retardant	UV Retardancy	Min. installation temperature
RFX 7/8"-50 RF2X 7/8"-50	Black, halogen free polyethylene	yes	no	no	yes	-40°C (-40°F)
RFX 7/8"-50 GHF RF2X 7/8"-50 GHF	Grey, halogen free fire retardant thermoplastic	yes	no	yes	no	-20°C (-4°F)
RFX 7/8"-50 BHF RF2X 7/8"-50 BHF	Black, halogen free fire retardant thermoplastic	yes	no	yes	yes	-20°C (-4°F)
RFX 7/8"-50 MBHF RF2X 7/8"-50 MBHF	Black, halogen free fire retardant thermoplastic with mica tape	yes	yes	yes	yes	-20°C (-4°F)

ELECTRICAL CHARACTERISTICS at +20°C (+ 68°F)

Characteristic impedance	50 ± 2 Ω	
Typical return loss (VSWR) on effective frequency range	18 dB	(1.29)
Velocity factor	0.90	
Capacitance	73 pF/m	(22.3 pF/ft)
Maximum frequency	5100 MHz	
DC-resistance		
• Inner conductor	1.11 Ω/km	(0.34 Ω/1000 ft)
• Outer conductor	1.11 Ω/km	(0.34 Ω/1000 ft)

**ATTENUATION
(measured acc. to IEC 61196-4 free space method)****RFX 7/8"-50**

at 75 MHz	1.2 dB/100 m	(0.37 dB/100 ft)
at 150 MHz	1.6 dB/100 m	(0.49 dB/100 ft)
at 450 MHz	3.0 dB/100 m	(0.91 dB/100 ft)
at 900 MHz	4.5 dB/100 m	(1.37 dB/100 ft)
at 1.8 GHz	6.9 dB/100 m	(2.10 dB/100 ft)
at 2.1 GHz	7.9 dB/100 m	(2.41 dB/100 ft)
at 2.4 GHz	8.6 dB/100 m	(2.62 dB/100 ft)

RF2X 7/8"-50

at 75 MHz	1.4 dB/100 m	(0.43 dB/100 ft)
at 150 MHz	1.8 dB/100 m	(0.55 dB/100 ft)
at 450 MHz	3.5 dB/100 m	(1.07 dB/100 ft)
at 900 MHz	5.4 dB/100 m	(1.65 dB/100 ft)
at 1.8 GHz	8.8 dB/100 m	(2.68 dB/100 ft)
at 2.1 GHz	10.0 dB/100 m	(3.05 dB/100 ft)
at 2.4 GHz	11.3 dB/100 m	(3.44 dB/100 ft)

**COUPLING LOSS
(measured acc. to IEC 61196-4 free space method)****RFX 7/8"-50** 50% value 95% value

at 75 MHz	51 dB	61 dB
at 150 MHz	63 dB	69 dB
at 450 MHz	69 dB	73 dB
at 900 MHz	70 dB	78 dB
at 1.8 GHz	72 dB	77 dB
at 2.1 GHz	71 dB	76 dB
at 2.4 GHz	77 dB	84 dB

RF2X 7/8"-50 50% value 95% value

at 75 MHz	49 dB	55 dB
at 150 MHz	57 dB	62 dB
at 450 MHz	62 dB	69 dB
at 900 MHz	64 dB	71 dB
at 1.8 GHz	65 dB	71 dB
at 2.1 GHz	67 dB	74 dB
at 2.4 GHz	68 dB	77 dB

STANDARD DRUM

Cable type	Drum	Standard length		Outer diam. (D)		Outer width (W)		Drum weight (empty) kg (lb)	Total weight kg (lb)	Drum freight volume m ³ (cu.ft)
		m	(ft)	cm	(in)	cm	(in)			
RFX 7/8"	P13G	500	(1640)	134	(52)	70	(28)	69 (152)	330 (728)	1.26 (44.50)

CODES FOR NKC CONNECTORS

Connector type	Code
7-16 male	NKC1078100
7-16 female	NKC1078200
7-16 Bulkhead female	NKC1078290
N male	NKC1078300
N female	NKC1078400
7-16 male Right angle	NKC1078500



Coaxial Antennas

RFX 1 1/4"-50

RF2X 1 1/4"-50

Specifications

COAXIAL CABLE	
Type	Code
RFX 1 1/4"-50	NKRFX11400
RFX 1 1/4"-50 GHF	NKRFX11401
RFX 1 1/4"-50 BHF	NKRFX11402
RF2X 1 1/4"-50	NKRFX2X11400
RF2X 1 1/4"-50 GHF	NKRFX2X11401
RF2X 1 1/4"-50 BHF	NKRFX2X11402

CONSTRUCTION

Inner conductor	Copper tube	Ø 13.0 mm	(0.51 in)
Dielectric	Cellular polyethylene	Ø 32.2 mm	(1.27 in)
Outer conductor	Corrugated slotted copper tube	Ø 35.8 mm	(1.41 in)
Jacket	See Jacketing Options table below	Ø 39.0 mm	(1.54 in)
Marking	Draka, cable type, manufacture week, year, batch number and meter mark		

MECHANICAL CHARACTERISTICS

Weight	0.86 kg/m	(0.58 lb/ft)
Maximum pulling force	6050 N	(1340 lb)
Minimum bending radius	350 mm	(14 in)
Operating temperature range	-55...+80°C	(-67...+176°F)
Recommended clamp spacing	1.5 m	(5 ft)

JACKETING OPTIONS						
Type	Jacket	IEC 60754-1/-2 halogen free, non corrosive	IEC 61034 low smoke emission	IEC 60332-3-24 fire retardant	UV Retardancy	Min. installation temperature
RFX 1 1/4"-50 RF2X 1 1/4"-50	Black, halogen free polyethylene	yes	no	no	yes	-40°C (-40°F)
RFX 1 1/4"-50 GHF RF2X 1 1/4"-50 GHF	Grey, halogen free fire retardant thermoplastic	yes	no	yes	no	-5°C (+23°F)
RFX 1 1/4"-50 BHF RF2X 1 1/4"-50 BHF	Black, halogen free fire retardant thermoplastic	yes	no	yes	yes	-5°C (+23°F)
RFX 1 1/4"-50 MBHF RF2X 1 1/4"-50 MBHF	Black, halogen free fire retardant thermoplastic with mica tape	yes	yes	yes	yes	-5°C (+23°F)

ELECTRICAL CHARACTERISTICS at +20°C (+ 68°F)

Characteristic impedance	50 ± 2 Ω	
Typical return loss (VSWR) on effective frequency range	18 dB	(1.29)
Velocity factor	0.88	
Capacitance	75 pF/m	(23 pF/ft)
Maximum frequency	3500 MHz	
DC-resistance		
• Inner conductor	0.74 Ω/km	(0.22 Ω/1000 ft)
• Outer conductor	0.65 Ω/km	(0.20 Ω/1000 ft)

**ATTENUATION
(measured acc. to IEC 61196-4 free space method)****RFX 1 1/4"-50**

at 75 MHz	0.9 dB/100 m	(0.27 dB/100 ft)
at 150 MHz	1.1 dB/100 m	(0.34 dB/100 ft)
at 450 MHz	2.2 dB/100 m	(0.67 dB/100 ft)
at 900 MHz	3.2 dB/100 m	(0.98 dB/100 ft)
at 1.8 GHz	5.4 dB/100 m	(1.65 dB/100 ft)
at 2.1 GHz	6.1 dB/100 m	(1.86 dB/100 ft)
at 2.4 GHz	6.8 dB/100 m	(2.07 dB/100 ft)

RF2X 1 1/4"-50

at 75 MHz	1.0 dB/100 m	(0.30 dB/100 ft)
at 150 MHz	1.4 dB/100 m	(0.43 dB/100 ft)
at 450 MHz	2.5 dB/100 m	(0.76 dB/100 ft)
at 900 MHz	4.1 dB/100 m	(1.25 dB/100 ft)
at 1.8 GHz	7.9 dB/100 m	(2.41 dB/100 ft)
at 2.1 GHz	9.1 dB/100 m	(2.77 dB/100 ft)
at 2.4 GHz	11.2 dB/100 m	(3.41 dB/100 ft)

**COUPLING LOSS
(measured acc. to IEC 61196-4 free space method)****RFX 1 1/4"-50** 50% value 95% value

at 75 MHz	53 dB	60 dB
at 150 MHz	62 dB	69 dB
at 450 MHz	70 dB	76 dB
at 900 MHz	71 dB	76 dB
at 1.8 GHz	71 dB	75 dB
at 2.1 GHz	68 dB	72 dB
at 2.4 GHz	68 dB	73 dB

RF2X 1 1/4"-50 50% value 95% value

at 75 MHz	47 dB	53 dB
at 150 MHz	54 dB	60 dB
at 450 MHz	64 dB	71 dB
at 900 MHz	64 dB	71 dB
at 1.8 GHz	64 dB	70 dB
at 2.1 GHz	65 dB	71 dB
at 2.4 GHz	64 dB	71 dB

STANDARD DRUM

Cable type	Drum	Standard length		Outer diam. (D) cm (in)	Outer width (W) cm (in)	Drum weight (empty) kg (lb)	Total weight kg (lb)	Drum freight volume m ³ (cu.ft)					
		m	(ft)										
RFX 1 1/4"	P20G	600	(1968)	204	(80)	70	(28)	155	(342)	717	(1584)	3.08	(108.76)

CODES FOR NKC CONNECTORS

Connector type	Code
7-16 male	NKC1114100
7-16 female	NKC1114200
7-16 Bulkhead female	NKC1114290
N male	NKC1114300
N female	NKC1114400



Coaxial Antennas

RFX 1 5/8"-50

RF2X 1 5/8"-50

Specifications

COAXIAL CABLE	
Type	Code
RFX 1 5/8"-50	NKRFX15800
RFX 1 5/8"-50 GHF	NKRFX15801
RFX 1 5/8"-50 BHF	NKRFX15802
RF2X 1 5/8"-50	NKRFX2X15800
RF2X 1 5/8"-50 GHF	NKRFX2X15801
RF2X 1 5/8"-50 BHF	NKRFX2X15802

CONSTRUCTION

Inner conductor	Corrugated copper tube	Ø 17.6 mm	(0.69 in)
Dielectric	Cellular polyethylene	Ø 42.0 mm	(1.65 in)
Outer conductor	Corrugated slotted copper tube	Ø 46.3 mm	(1.82 in)
Jacket	See Jacketing Options table below	Ø 50.0 mm	(1.97 in)
Marking	Draka, cable type, manufacture week, year, batch number and meter mark		

MECHANICAL CHARACTERISTICS

Weight	1.13 kg/m	(0.76 lb/ft)
Maximum pulling force	3750 N	(826 lb)
Minimum single bending radius	400 mm	(15.7 in)
Operating temperature range	-55...+80°C	(-67...+176°F)
Recommended clamp spacing	1.5 m	(5 ft)

JACKETING OPTIONS						
Type	Jacket	IEC 60754 -1/-2 halogen free, non corrosive	IEC 61034 low smoke emission	IEC 60332-3-24 fire retardant	UV Retardancy	Min. installation temperature
RFX 1 5/8"-50 RF2X 1 5/8"-50	Black, halogen free polyethylene	yes	no	no	yes	-40°C (-40°F)
RFX 1 5/8"-50 GHF RF2X 1 5/8"-50 GHF	Grey, halogen free fire retardant thermoplastic	yes	no	yes	no	-5°C (+23°F)
RFX 1 5/8"-50 BHF RF2X 1 5/8"-50 BHF	Black, halogen free fire retardant thermoplastic	yes	no	yes	yes	-5°C (+23°F)
RFX 1 5/8"-50 MBHF RF2X 1 5/8"-50 MBHF	Black, halogen free fire retardant thermoplastic with mica tape	yes	yes	yes	yes	-5°C (+23°F)

ELECTRICAL CHARACTERISTICS at +20°C (+ 68°F)

Characteristic impedance	50 ± 2 Ω	
Typical return loss (VSWR) on effective frequency range	18 dB	(1.29)
Velocity factor	0.89	
Capacitance	74 pF/m	(22.6 pF/ft)
Maximum frequency	2800 MHz	
DC-resistance		
• Inner conductor	1.16 Ω/km	(0.35 Ω/1000 ft)
• Outer conductor	0.43 Ω/km	(0.13 Ω/1000 ft)

**ATTENUATION
(measured acc. to IEC 61196-4 free space method)****RFX 1 5/8"-50**

at 75 MHz	0.7 dB/100 m	(0.21 dB/100 ft)
at 150 MHz	0.9 dB/100 m	(0.27 dB/100 ft)
at 450 MHz	1.7 dB/100 m	(0.52 dB/100 ft)
at 900 MHz	2.7 dB/100 m	(0.82 dB/100 ft)
at 1.8 GHz	4.6 dB/100 m	(1.40 dB/100 ft)
at 2.1 GHz	5.2 dB/100 m	(1.58 dB/100 ft)
at 2.4 GHz	6.2 dB/100 m	(1.89 dB/100 ft)

RF2X 1 5/8"-50

at 75 MHz	0.7 dB/100 m	(0.21 dB/100 ft)
at 150 MHz	1.0 dB/100 m	(0.30 dB/100 ft)
at 450 MHz	1.9 dB/100 m	(0.58 dB/100 ft)
at 900 MHz	3.0 dB/100 m	(0.91 dB/100 ft)
at 1.8 GHz	5.5 dB/100 m	(1.68 dB/100 ft)
at 2.1 GHz	6.4 dB/100 m	(1.95 dB/100 ft)
at 2.4 GHz	7.5 dB/100 m	(2.29 dB/100 ft)

**COUPLING LOSS
(measured acc. to IEC 61196-4 free space method)****RFX 1 5/8"-50**

	50% value	95% value
at 75 MHz	53 dB	60 dB
at 150 MHz	63 dB	69 dB
at 450 MHz	68 dB	73 dB
at 900 MHz	68 dB	73 dB
at 1.8 GHz	69 dB	75 dB
at 2.1 GHz	67 dB	72 dB
at 2.4 GHz	68 dB	74 dB

RF2X 1 5/8"-50

	50% value	95% value
at 75 MHz	50 dB	56 dB
at 150 MHz	58 dB	63 dB
at 450 MHz	63 dB	67 dB
at 900 MHz	64 dB	72 dB
at 1.8 GHz	66 dB	73 dB
at 2.1 GHz	65 dB	72 dB
at 2.4 GHz	66 dB	74 dB

STANDARD DRUM

Cable type	Drum	Standard length		Outer diam. (D)		Outer width (W)		Drum weight (empty) kg (lb)	Total weight kg (lb)	Drum freight volume m ³ (cu.ft)
		m	(ft)	cm	(in)	cm	(in)			
RFX 1 5/8"	P20G	400	(1312)	204	(80)	70	(28)	155 (342)	653 (1440)	3.08 (108.76)

CODES FOR NKC CONNECTORS

Connector type	Code
7-16 male	NKC1158100
7-16 female	NKC1158200
7-16 Bulkhead female	NKC1158290
N male	NKC1158300
N female	NKC1158400

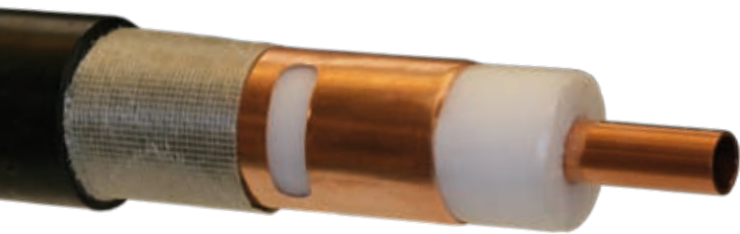

Coaxial Antennas

RFXT 7/8"-50

MBHF

Specifications

COAXIAL CABLE	
Type	Code
RFXT 7/8"-50 MGHF	NKRFXTO7806
RFXT 7/8"-50 MBHF	NKRFXTO7807

CONSTRUCTION

Inner conductor	Copper tube	Ø 9.0 mm	(0.35 in)
Dielectric	Cellular polyethylene	Ø 23.2 mm	(0.91 in)
Outer conductor	Copper tape with periodic slots	Ø 23.5 mm	(0.93 in)
Fire barrier	Mica tape	Ø 23.7 mm	(0.93 in)
Jacket	See Jacketing Options table below	Ø 28.7 mm	(1.13 in)
Marking	Draka, cable type, manufacture week, year, batch number and meter mark		

ELECTRICAL CHARACTERISTICS at +20°C (+ 68°F)

Characteristic impedance	50 ± 2 Ω	
Typical return loss (VSWR) on effective frequency range	18 dB	(1.29)
Velocity factor	0.88	
Capacitance	76 pF/m	(23 pF/ft)
Maximum frequency	5100 MHz	
DC-resistance		
• Inner conductor	1.16 Ω/km	(0.35 Ω/1000 ft)
• Outer conductor	1.11 Ω/km	(0.45 Ω/1000 ft)

JACKETING OPTIONS						
Type	Jacket	IEC 60754 -1/-2 halogen free, non corrosive	IEC 61034 low smoke emission	IEC 60332-3-24 fire retardant	UV Retardancy	Min. installation temperature
RFXT 7/8"-50 MGHF	Grey, halogen free fire retardant thermoplastic with mica tape	yes	yes	yes	no	-20°C (-4°F)
RFXT 7/8"-50 MBHF	Black, halogen free fire retardant thermoplastic with mica tape	yes	yes	yes	yes	-20°C (-4°F)

MECHANICAL CHARACTERISTICS

Weight	0.66 kg/m	(0.44 lb/ft)
Maximum pulling force	2300 N	(507 lb)
Minimum single bending radius	400 mm	(17 in)
Operating temperature range	-55...+80°C	(-67...+176°F)
Recommended clamp spacing	1.0 m	(3.3 ft)

ATTENUATION

(measured acc. to IEC 61196-4 free space method)

at 150 MHz	1.9 dB/100m	(0.58 dB/100ft)
at 450 MHz	3.2 dB/100m	(0.98 dB/100ft)
at 900 MHz	5.0 dB/100m	(1.52 dB/100ft)
at 1.8 GHz	8.0 dB/100m	(2.44 dB/100ft)

COUPLING LOSS

(measured acc. to IEC 61196-4 free space method)

	50% value	95% value
at 150 MHz	70 dB	76 dB
at 450 MHz	65 dB	68 dB
at 900 MHz	65 dB	71 dB
at 1.8 GHz	67 dB	72 dB

STANDARD DRUM

Cable type	Drum	Standard length		Outer diam. (D)		Outer width (W)		Drum weight (empty) kg (lb)	Total weight kg (lb)	Drum freight volume m ³ (cu.ft)
		m	(ft)	cm	(in)	cm	(in)			
RFXT 7/8"	P20G	500	(1640)	204	(80)	70	(28)	155 (342)	531 (1170)	3.08 (108.76)

CODES FOR NKC CONNECTORS

Connector type	Code
7-16 male	NKC3078120
7-16 female	NKC3078220
N male	NKC3078320
N female	NKC3078420

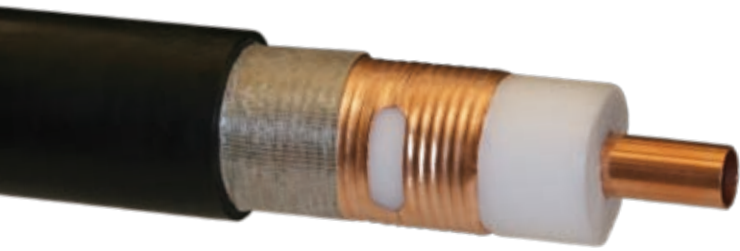

Coaxial Antennas

RFXT 1 1/4"-50

MBHF

Specifications

COAXIAL CABLE	
Type	Code
RFXT 1 1/4"-50 MGHF	NKRFX11406
RFXT 1 1/4"-50 MBHF	NKRFX11407

CONSTRUCTION

Inner conductor	Copper tube	Ø 12.8 mm	(0.50 in)
Dielectric	Cellular polyethylene	Ø 32.5 mm	(1.28 in)
Outer conductor	Copper tape with periodic slots	Ø 32.8 mm	(1.29 in)
Fire barrier	Mica tape	Ø 33.0 mm	(1.30 in)
Jacket	See Jacketing Options table below	Ø 38.8 mm	(1.53 in)
Marking	Draka, cable type, manufacture week, year, batch number and meter mark		

ELECTRICAL CHARACTERISTICS at +20°C (+ 68°F)

Characteristic impedance	50 ± 2 Ω	
Typical return loss (VSWR) on effective frequency range	18 dB	(1.29)
Velocity factor	0.88	
Capacitance	76 pF/m	(23 pF/ft)
Maximum frequency	3500 MHz	
DC-resistance		
• Inner conductor	0.63 Ω/km	(0.19 Ω/1000 ft)
• Outer conductor	1.14 Ω/km	(0.35 Ω/1000 ft)

JACKETING OPTIONS						
Type	Jacket	IEC 60754-1/-2 halogen free, non corrosive	IEC 61034 low smoke emission	IEC 60332-3-24 fire retardant	UV Retardancy	Min. installation temperature
RFXT 1 1/4"-50 MGHF	Grey, halogen free fire retardant thermoplastic with mica tape	yes	yes	yes	no	-5°C (+23°F)
RFXT 1 1/4"-50 MBHF	Black, halogen free fire retardant thermoplastic with mica tape	yes	yes	yes	yes	-5°C (+23°F)

MECHANICAL CHARACTERISTICS

Weight	0.910 kg/m	(0.61 lb/ft)
Maximum pulling force	3000 N	(664 lb)
Minimum single bending radius	450 mm	(18 in)
Operating temperature range	-55...+80°C	(-67...+176°F)
Recommended clamp spacing	1.5 m	(5 ft)

ATTENUATION

(measured acc. to IEC 61196-4 free space method)

at 150 MHz	1.1 dB/100m	(0.34 dB/100ft)
at 450 MHz	2.1 dB/100m	(0.64 dB/100ft)
at 900 MHz	3.0 dB/100m	(0.91 dB/100ft)
at 1.8 GHz	5.2 dB/100m	(1.59 dB/100ft)

COUPLING LOSS

(measured acc. to IEC 61196-4 free space method)

	50% value	95% value
at 150 MHz	76 dB	82 dB
at 450 MHz	67 dB	74 dB
at 900 MHz	69 dB	75 dB
at 1.8 GHz	64 dB	70 dB

STANDARD DRUM

Cable type	Drum	Standard length		Outer diam. (D)		Outer width (W)		Drum weight (empty) kg (lb)	Total weight kg (lb)	Drum freight volume m ³ (cu.ft)
		m	(ft)	cm	(in)	cm	(in)			
RFXT 1 1/4"	P19Q	500	(1640)	194	(76)	102	(40)	141 (311)	672 (1478)	3.99 (140.89)

CODES FOR NKC CONNECTORS

Connector type	Code
7-16 male	NKC3114120
7-16 female	NKC3114220
N male	NKC3114320
N female	NKC3114420

Jumpers



Jumpers with superflexible RFF 1/2" cable

Draka jumper cables are the perfect choice for antenna line connections. Our jumpers have excellent return loss values with low and stable intermodulation.

Stable electrical performance is ensured by high quality superflexible cable and special connector head design. Soldered inner and outer conductor guarantees excellent return loss and low intermodulation.

The design of the assembly ensures the waterproofness of the jumper to IP 68. The design is based on three main principles:

- 7-16 head sealing with O-rings
- Induction soldering of the inner and outer conductors providing 360 degrees of contact and sealing
- Enclosing the connection at the rear of the connector with injection molded body

All our jumpers are delivered with an attached test report. Additional protection is maintained during storage and transport by a watertight protective cap on each end.



Product : NKJ113 Jumper 1,5 m RFF 1/2" 7/16 m-m
 Measured: 05112087 (JM)
 W1201363-883
 CS72681.01

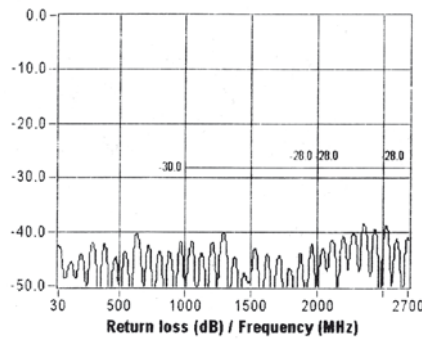

A test report shows return loss measurements. For traceability, a weatherproof ID label is attached to each jumper.

JUMPERS										
		RFF 1/2" cable length								
Connectors			0.5 m	1 m	1.5 m	2 m	2.5 m	3 m	4 m	5 m
Male 7/16	Male 7/16	NKJ 11	NKJ 111	NKJ 112	NKJ 113	NKJ 114	NKJ 115	NKJ 116	NKJ 118	NKJ 1110
Male 7/16	Female 7/16	NKJ 12	NKJ 121	NKJ 122	NKJ 123	NKJ 124	NKJ 125	NKJ 126	NKJ 128	NKJ 1210
Male 7/16	Male N	NKJ 13	NKJ 131	NKJ 132	NKJ 133	NKJ 134	NKJ 135	NKJ 136	NKJ 138	NKJ 1310
Male 7/16	Female N	NKJ 14	NKJ 141	NKJ 142	NKJ 143	NKJ 144	NKJ 145	NKJ 146	NKJ 148	NKJ 1410
Male 7/16	Male 7/16 90°	NKJ 15	NKJ 151	NKJ 152	NKJ 153	NKJ 154	NKJ 155	NKJ 156	NKJ 158	NKJ 1510
Male 7/16	Male N 90°	NKJ 16	NKJ 161	NKJ 162	NKJ 163	NKJ 164	NKJ 165	NKJ 166	NKJ 168	NKJ 1610
Female 7/16	Female 7/16	NKJ 22	NKJ 221	NKJ 222	NKJ 223	NKJ 224	NKJ 225	NKJ 226	NKJ 228	NKJ 2210
Female 7/16	Male N	NKJ 23	NKJ 231	NKJ 232	NKJ 233	NKJ 234	NKJ 235	NKJ 236	NKJ 238	NKJ 2310
Female 7/16	Female N	NKJ 24	NKJ 241	NKJ 242	NKJ 243	NKJ 244	NKJ 245	NKJ 246	NKJ 248	NKJ 2410
Female 7/16	Male 7/16 90°	NKJ 25	NKJ 251	NKJ 252	NKJ 253	NKJ 254	NKJ 255	NKJ 256	NKJ 258	NKJ 2510
Female 7/16	Male N 90°	NKJ 26	NKJ 261	NKJ 262	NKJ 263	NKJ 264	NKJ 265	NKJ 266	NKJ 268	NKJ 2610
Male N	Male N	NKJ 33	NKJ 331	NKJ 332	NKJ 333	NKJ 334	NKJ 335	NKJ 336	NKJ 338	NKJ 3310
Male N	Female N	NKJ 34	NKJ 341	NKJ 342	NKJ 343	NKJ 344	NKJ 345	NKJ 346	NKJ 348	NKJ 3410
Male N	Male 7/16 90°	NKJ 35	NKJ 351	NKJ 352	NKJ 353	NKJ 354	NKJ 355	NKJ 356	NKJ 358	NKJ 3510
Male N	Male N 90°	NKJ 36	NKJ 361	NKJ 362	NKJ 363	NKJ 364	NKJ 365	NKJ 366	NKJ 368	NKJ 3610
Female N	Female N	NKJ 44	NKJ 441	NKJ 442	NKJ 443	NKJ 444	NKJ 445	NKJ 446	NKJ 448	NKJ 4410
Female N	Male 7/16 90°	NKJ 45	NKJ 451	NKJ 452	NKJ 453	NKJ 454	NKJ 455	NKJ 456	NKJ 458	NKJ 4510
Female N	Male N 90°	NKJ 46	NKJ 461	NKJ 462	NKJ 463	NKJ 464	NKJ 465	NKJ 466	NKJ 468	NKJ 4610

Fire retardant jumpers for indoor applications are also available.

Accessories



Draka offers a wide variety of high quality accessories that are easy to install. The accessories are guaranteed to be compatible with Draka products. They are tested and reliable in all relevant environmental conditions. For more accessories and further details, please contact our sales personnel.

FEEDER CABLES

Connectors	RFA 1/4"	RFA 3/8"	RFA 1/2"	RFA 7/8"	RFA 7/8" AL	RFA 1 1/4"	RFA 1 5/8"	RFA 1 5/8" AL	RFA 2 1/4"
7-16 male	NKC1014100	NKC1038100	NKC1012100	NKC1078100	NKC1078100	NKC1114100	NKC1158100	NKC1158100	NKC1214100
7-16 female	-	NKC1038200	NKC1012200	NKC1078200	NKC1078200	NKC1114200	NKC1158200	NKC1158200	NKC1214200
7-16 male right angle	-	-	NKC1012500	NKC1078500	NKC1078500	-	-	-	-
N-male	NKC1014300	NKC1038300	NKC1012300	NKC1078300	NKC1078300	NKC1114300	NKC1158300	NKC1158300	NKC1214300
N-female	NKC1014400	NKC1038400	NKC1012400	NKC1078400	NKC1078400	NKC1114400	NKC1158400	NKC1158400	NKC1214400
N-male right angle	NKC1014600	-	NKC1012600	-	-	-	-	-	-

GROUNDING KITS

Grounding kit	NKG201400	NKG203800	NKG101200	NKG107800	NKG107800	NKG111400	NKG115800	NKG115800	NKG121400

TOOLS

Manual tools	NKA1010	NKA1000	NKA1001	NKA1003	NKA1003	NKA1004	NKA1004 and NKA1005	NKA1004 and NKA1005	NKA1005
Drill tools	-	-	NKA12012	NKA12078	NKA12078	NKA12114	NKA12158	NKA12158	NKA12214
Grounding kit tools (Stripping length, mm)	-	-	NKA1401222 (22)	NKA1407822 (22)	NKA1407822 (22)	NKA1411422 (22)	NKA1415822 (22)	NKA1415822 (22)	-
Grounding kit tools (Stripping length, mm)	-	-	NKA1401226 (26)	NKA1407826 (26)	NKA1407826 (26)	NKA1411430 (30)	NKA1415830 (30)	NKA1415830 (30)	-



Connectors

- Low intermodulation
- Primary weatherproofness with O-ring technology



Tools

- Reduced assembly time
- Guarantee of constant assembly quality



Grounding Kits

- Fast and easy to install
- Waterproof per IP 68
- Reusable



Weatherproofing Kits

- protects connections from weather conditions

EMP-Protectors

- One-piece, easy and rapid installation
- No maintenance required

EMP PROTECTOR	
Product	Quarter-wave, gas capsule and hybrid surge protectors to Tetra, GSM900/1800 and UMTS communication solutions
Code	NKA3000

SUPERFLEXIBLE CABLES						
Connectors	RFF 1/4"	RFF 3/8"	RFF 1/2"	RFE 7/8"	RFE 1 1/4"	RFE 1 5/8"
7-16 male	NKC2014120	NKC2038100	NKC2012100	NKC1078100	NKC1114100	NKC1158100
7-16 female	NKC2014220	NKC2038200	NKC2012200	NKC1078200	NKC1114200	NKC1158200
7-16 male right angle	-	-	NKC2012300	NKC1078500	-	-
N-male	NKC2014320	NKC2038300	NKC2012400	NKC1078300	NKC1114300	NKC1158300
N-female	NKC2014420	NKC2038400	NKC2012500	NKC1078400	NKC1114400	NKC1158400
N-male right angle	NKC2014620	NKC2038600	NKC2012600	-	-	-

GROUNDING KITS						
Grounding kit	NKG201400	NKG203800	NKG201200	NKG107800	NKG111400	NKG115800

TOOLS						
Manual tools	NKA1007	NKA1008	NKA1009	NKA1003	NKA1004 and NKA1005	NKA1004 and NKA1005
Drill tools	-	-	NKA22012	NKA12078	NKA12114	NKA12158
Grounding kit tools (Stripping length, mm)	-	-	NKA1401222 (22)	NKA1407822 (22)	NKA1411422 (22)	NKA1415822 (22)
Grounding kit tools (Stripping length, mm)	-	-	NKA1401226 (26)	NKA1407826 (26)	NKA1411430 (30)	NKA1415830 (30)

Drums



Our tailor-made wooden cable drums are designed to meet all transportation requirements to give the best protection for our cables. The drums are made of barkless boards or plywood. They are marked with an identification mark, according to the international plant protection convention (IPPC) regulations. Special drums are available on request.

Handling and transport of our drums:

- Handling instructions are attached on each drum.
- The reeling direction of the cable is indicated by an arrow.
- For transportation and storage the cable is protected by wooden lagging.
- Plastic covering is placed over the outer layer of the cable, beneath the lagging.
- Cable ends are sealed with a shrinkable plastic tube.

Loading instructions are available on DVD. Please contact our sales offices for these instructions.



Example of the wood packaging material (WPM) mark on the cable drum.

① DRAKA NK CABLES LTD		
RFA 7/8-50		
NR CODE: L718414	Cable Identification	
NR WORK NUMBER: 1119038	2289N	④ 3CH55
② CASE NUMBER: 2289N	GROSS KG: 342	NET KG: 246
LENGTH: 500	OUTER END(S): 500	INNER END(S): 0

Drum label shows

- 1 cable type
- 2 length
- 3 gross weight
- 4 batch number

STANDARD DRUMS FOR CABLES

Cable type	Drum	Standard length		Outer diam. (D) cm (in)	Inner diam. (d) cm (in)	Outer width (W) cm (in)	Inner width (w) cm (in)	Shaft hole (e) cm (in)	Drum weight (empty) kg (lb)	Ladding weight kg (lb)	Cable weight kg/m (lb/ft)	Total weight kg (lb)	Drum freight volume m ³ (cu.ft)										
		m	ft																				
RFA 1/4"	P6D	500	(1640)	63	(25)	33	(13)	51	(20)	43	(17)	8.2	(3.2)	13	(29)	9.5	(21)	0.12	(0.08)	83	(183)	0.20	(7.06)
RFA 3/8"	P6D	250	(820)	63	(25)	33	(13)	51	(20)	43	(17)	8.2	(3.2)	13	(29)	9.5	(21)	0.13	(0.08)	55	(117)	0.20	(7.06)
RFA 1/2"	P11D	500	(1640)	114	(45)	70	(28)	51	(20)	43	(17)	8.2	(3.2)	45	(99)	15.5	(34)	0.23	(0.15)	176	(379)	0.66	(23.31)
RFA 7/8"	P13G	500	(1640)	134	(52)	75	(29)	70	(28)	61	(24)	8.2	(3.2)	69	(152)	31	(68)	0.49	(0.33)	343	(760)	1.26	(44.50)
RFA 7/8" AL	P13G	500	(1640)	134	(52)	75	(29)	70	(28)	61	(24)	8.2	(3.2)	69	(152)	31	(68)	0.37	(0.25)	285	(630)	1.26	(44.50)
RFA 1 1/4"	P20G	600	(1968)	204	(80)	120	(47)	70	(28)	61	(24)	8.2	(3.2)	155	(342)	46	(101)	0.89	(0.60)	735	(1621)	3.08	(108.76)
RFA 1 5/8"	P20G	400	(1312)	204	(80)	120	(47)	70	(28)	61	(24)	8.2	(3.2)	155	(342)	46	(101)	1.16	(0.78)	665	(1466)	3.08	(108.76)
RFA 1 5/8" AL	P20G	400	(1312)	204	(80)	120	(47)	70	(28)	61	(24)	8.2	(3.2)	155	(342)	46	(101)	1.16	(0.78)	665	(1466)	3.08	(108.76)
RFA 2 1/4"	P21Q	300	(984)	214	(84)	150	(59)	105	(41)	96	(38)	8.2	(3.2)	218	(481)	87	(192)	1.93	(1.30)	884	(1952)	5.40	(190.68)
RFF 1/4"	P5C	250	(820)	53	(21)	25	(10)	50	(20)	40	(16)	8.2	(3.2)	9	(20)	5.5	(12)	0.09	(0.06)	37	(81)	0.14	(4.94)
RFF 3/8"	P5C	250	(820)	53	(21)	25	(10)	50	(20)	40	(16)	8.2	(3.2)	9	(20)	5.5	(12)	0.12	(0.08)	45	(98)	0.14	(4.94)
RFF 1/2"	P11D	500	(1640)	114	(45)	70	(28)	51	(20)	43	(17)	8.2	(3.2)	45	(99)	15.5	(34)	0.19	(0.13)	156	(346)	0.66	(23.31)
RFE 7/8"	P13G	500	(1640)	134	(52)	75	(29)	70	(28)	61	(24)	8.2	(3.2)	69	(152)	31	(68)	0.43	(0.29)	315	(696)	1.24	(44.50)
RFE 1 1/4"	P20G	600	(1968)	204	(80)	120	(47)	70	(28)	61	(24)	8.2	(3.2)	155	(342)	46	(101)	0.79	(0.53)	675	(1486)	3.08	(108.76)
RFE 1 5/8"	P20G	400	(1312)	204	(80)	120	(47)	70	(28)	61	(24)	8.2	(3.2)	155	(342)	46	(101)	1.19	(0.80)	677	(1492)	3.08	(108.76)
RFX 1/2"	P11D	500	(1640)	114	(45)	70	(28)	51	(20)	43	(17)	8.2	(3.2)	45	(99)	15.5	(34)	0.22	(0.15)	170	(375)	0.66	(23.31)
RFX 7/8"	P13G	500	(1640)	134	(52)	75	(29)	70	(28)	61	(24)	8.2	(3.2)	69	(152)	31	(68)	0.46	(0.31)	330	(728)	1.26	(44.50)
RFX 1 1/4"	P20G	600	(1968)	204	(80)	120	(47)	70	(28)	61	(24)	8.2	(3.2)	155	(342)	46	(101)	0.86	(0.58)	717	(1584)	3.08	(108.76)
RFX 1 5/8"	P20G	400	(1312)	204	(80)	120	(47)	70	(28)	61	(24)	8.2	(3.2)	155	(342)	46	(101)	1.13	(0.76)	653	(1440)	3.08	(108.76)
RFXT 7/8"	P20G	500	(1640)	204	(80)	120	(47)	70	(28)	61	(24)	8.2	(3.2)	155	(342)	46	(101)	0.66	(0.44)	531	(1170)	3.08	(108.76)
RFXT 1 1/4"	P19Q	500	(1640)	194	(76)	130	(51)	102	(40)	93	(37)	8.2	(3.2)	141	(311)	76	(167)	0.91	(0.61)	672	(1478)	3.99	(140.89)

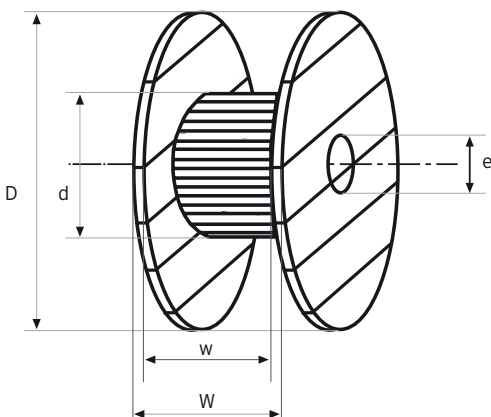

Environment and Quality



Environmental Management System

Draka is committed to sustainable development. Operations and products are undergoing continuous development with an eye on reducing environmental load.

Our environmental management system has been assessed, approved and audited regularly to ISO 14001:2004 Environmental Management System Standard.

Environmental Statement

The Environmental Policy of Draka aims at

- following environmental protection legislation and regulations.
- reducing adverse environmental impacts during the whole life cycle.
- preventing environmental pollution and increasing recovery and recycling.
- raising environmental awareness of the entire personnel through training and reviewing.
- encouraging material suppliers and contractors to sustainable development activities.
- openly reporting the environmental impacts of its activities and products.

Quality Management System

The quality systems of Draka companies assessed, approved and audited regularly by certification companies are against ISO 9001. Compliance with ISO 9001:2000 standard guarantees the quality and continuous improvement of our processes. Our cables are released only after successful testing according to the appropriate requirements.

The quality management systems are open to customers' evaluation.

Quality Statement

Draka commits to

- fulfill customers' expectations in all processes.
- provide customers with satisfying products on time.
- perform customer service properly.
- improve our processes constantly.
- a quality concept covering everything from the products and services to overall operations.



Environment and Quality



 **Draka** TEST REPORT

Band: A

Cable type.....:RFA 1/2"-50
 Art number.....:720437
 Cable number.....:1200194-4L3G6
 Insulation number.....:0010449719
 Drum number.....:P11D 44961N
 Cable Length.....:500 m
 Electrical length.....:1945 ns
 Voltage test.....:PASS (4.6 kV DC/60 s)
 Impedance.....:PASS 50.1 ohm (49.0 - 51.0)
 Corrugation diameter.....:PASS Inner 13.8 mm, Outer 13.8 mm (13.8 - 14.0)
 Outer diameter.....:PASS Inner 16.1 mm, Outer 16.1 mm (15.6 - 16.4)
 Eccentricity inner/outer.:PASS / PASS
 Corr. Depth inner/outer.:PASS / PASS

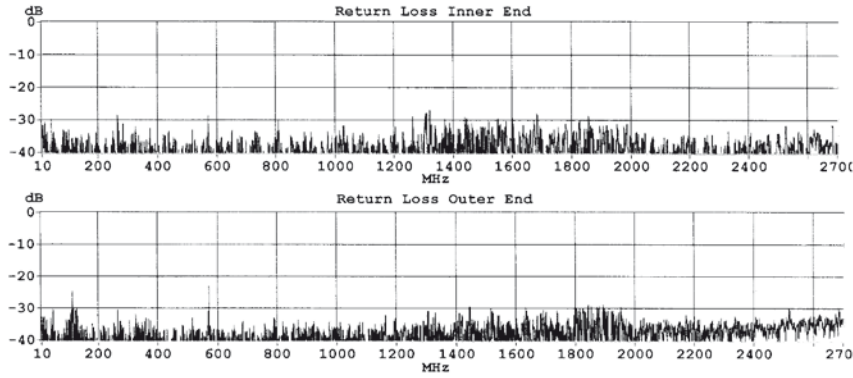

Maximum return loss			Inner End		Outer End		Result
Band	Start-Stop (MHz)	Req (dB)	MHz	dB	MHz	dB	
A	10 2700	21.0	1321	26.8	572	22.9	PASS
B	380 500	21.0	438	33.4	483	35.3	PASS
C	806 960	21.0	810	30.1	871	33.7	PASS
D	1710 1880	21.0	1857	28.8	1827	28.5	PASS
G	1900 2170	21.0	1955	31.0	1954	29.6	PASS

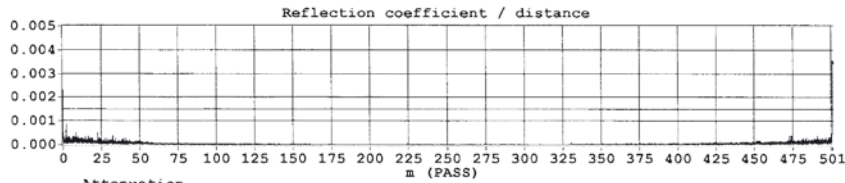

Attenuation			
Freq (MHz)	Limit (dB/100m)	Att. (dB/100m)	Result
400	4.57	4.50	PASS
500	5.16	5.07	PASS
800	6.68	6.50	PASS
900	7.14	6.93	PASS
1000	7.57	7.33	PASS
1800	10.60	10.09	PASS
1900	10.90	10.48	PASS
2200	11.90	11.42	PASS

Test Report

A test report is attached to each cable drum delivered by Draka. The test report includes identification data of the cable and drum, test results of transmission characteristics and other electrical characteristics as well as test results of mechanical dimensions of the cable.

Characteristic impedance is a routine measurement and it is derived from the electrical length and capacitance measurements. The tolerance in feeder cables is 50+/- 1Ω.

High voltage tests verify that no breakdown occurs in insulation or jacket when high voltages are applied.

Return loss sums up the effects of all the

impedance variations within the cable and at its ends, at a certain frequency. The return loss is measured from both ends of the cable at 10-2700 MHz frequency band.

Attenuation is determined from the ratio of the input and output power. The test report contains the attenuation values at 400, 500, 800, 900, 1000, 1800, 1900 and 2200 MHz frequencies.

We also carry out a TDR (Time Domain Reflectometry) measurement in order to verify that there are no local damages in the cable.

How to contact us



How to contact us

Our worldwide network of partners and local offices are at your service. To find out the closest partner to you, please contact our main sales offices in Finland, Singapore or China.

FINLAND

Draka NK Cables Ltd.

Office:

Kimmeltie 1
FI-02110 Espoo
Tel. +358 10 56 61
Fax. +358 9 52 98 41
E-mail: mnc-sales@draka.com

Oulu Plant:

Johdintie 5
FI-90630 Oulu
Tel. +358 10 56 61

SINGAPORE

Draka NK Cables (Asia) Pte Ltd.

171 Chin Swee Road
#12-05 San Centre
Singapore 169877
Tel. +65 65 33 20 12
Fax. +65 65 33 20 26
sales@nkcables.com.sg

CHINA

NK Wuhan Cable Co. Ltd.

DongXin Road Guanshan
430073 Wuhan
China
Tel. +86 27 87 77 05 33
Fax. +86 27 87 80 60 90

For more information, please visit us at www.draka.com.



Draka

www.draka.com

